

**TECHNICAL MANUAL
OPERATOR, ORGANIZATIONAL, DIRECT
SUPPORT & GENERAL SUPPORT
MAINTENANCE MANUAL INCLUDING
REPAIR PARTS LIST
FOR
CLEANER, STEAM PRESSURE
JET SKID MOUNTED
MODEL: RI 2400
(NSN 4940-00-186-0027)**

HEADQUARTERS, DEPARTMENT OF THE ARMY

WARNING

THIS MACHINE MUST BE PROPERLY GROUNDED TO AVOID FATAL ELECTRICAL SHOCK .

DISCONNECT THE MACHINE FROM ELECTRICAL SOURCE BEFORE MAKING ANY REPAIRS .

UNIT IS DESIGNED TO PRODUCE VERY HIGH PRESSURE AND/OR TEMPERATURE AT GUN TIP. TO PREVENT INJURY OR DAMAGE, HOLD CLEANING GUN SECURELY AT ALL TIMES.

OPEN FLAME AND CONTINUOUS ELECTRICAL SPARK PRESENT DURING OPERATION . TO AVOID FIRE AND/OR EXPLOSION, DO NOT OPERATE THIS UNIT IN COMBUSTIBLE ATMOSPHERE OR ADJACENT TO COMBUSTIBLE MATERIALS OR LIQUIDS.

WEAR PROTECTIVE CLOTHING INCLUDING FACE MASK WHEN OPERATING

CHECK CLEANING HOSE, FITTINGS, SPUDS AND CLAMPS PRIOR TO OPERATION. DO NOT OPERATE UNIT WITH DAMAGED OR WORN HOSE.

DO NOT REPAIR DAMAGED HOSE AND/OR FITTINGS. REPLACE WITH FITTINGS AND/OR HOSE WHICH MEETS OR EXCEEDS SPECIFICATIONS OF ORIGINAL EQUIPMENT.

ALWAYS RELEASE PRESSURE IN CLEANING HOSE PRIOR TO DISCONNECTING FROM UNIT OR CLEANING GUN.

NEVER REMOVE ANY HOSE WHILE MACHINE IS ON.

ALWAYS CHECK ELECTRICAL SUPPLY TO BE CERTAIN IT IS COMPATIBLE WITH EQUIPMENT REQUIREMENTS.

NEVER POINT THE CLEANING WAND AT ANY PERSONNEL.

DURING BLOW DOWN PROCEDURES, DO NOT PERMIT ANY PERSONNEL CLOSER THAN 15 FEET FROM BLOW DOWN DISCHARGE SIDE OF UNIT.

UNIT MUST BE VENTED OUTSIDE WHEN OPERATED INSIDE. REF TO 1.5.2.

DO NOT OPERATE WITH PROTECTIVE COVERS AND GUARDS REMOVED. THERE ARE HAZARDOUS VOLTAGES AND RAPIDLY MOVING PARTS.

DO NOT OPERATE WITH ELECTRICAL PANEL OPEN. ONLY QUALIFIED PERSONNEL SHOULD ATTEMPT ELECTRICAL TROUBLE SHOOTING AND REPAIR.

RELIEVE SYSTEM PRESSURE FROM WATER SYSTEM USING THE RELIEF VALVE PRIOR TO MAKING ANY REPAIR.

WARNING

DO NOT ALLOW UNIT TO OPERATE UN-ATTENDED.

DO NOT OPERATE UNIT WITH ANY SAFETY CONTROL BY-PASSED.

DO NOT PERMIT ANY UN-TRAINED PERSONNEL TO OPERATE THIS UNIT.

DO NOT PERMIT ANY UN-TRAINED PERSONNEL TO MAINTAIN OR MAKE REPAIRS ON THIS UNIT.

USE ONLY NUMBER 1 OR NUMBER 2 DIESEL FUEL IN FUEL TANK - NEVER GASOLINE.

USE ONLY CLEANING COMPOUND CONFORMING TO MIL-C-22542. USE OF OTHER COMPOUNDS MAY RESULT IN FIRE HAZARD.

PROVIDE ADEQUATE FRESH AIR TO UNIT DURING OPERATION.

THIS UNIT HAS BEEN MANUFACTURED TO MEET ULTRA HIGH TEMPERATURE OUTPUT REQUIREMENTS FOR THE UNITED STATES GOVERNMENT. BECAUSE OF THESE HIGH TEMPERATURE OUTLET REQUIREMENTS, USE BY CIVILIAN PERSONNEL MAY REQUIRE THAT SUCH OPERATION BE SUPERVISED BY LICENSED STATIONARY (BOILER) ENGINEER.

THIS UNIT DOES NOT MEET BOILER CODES. CONTACT FACTORY FOR ADJUSTMENT INSTRUCTIONS IF UNIT IS TO BE USED BY CIVILIAN PERSONNEL.

DO NOT ALLOW UNIT TO STEAM WITH COIL CONDITIONER CIRCULATING. PERSONAL INJURY OR DEATH MAY RESULT FROM THE FUMES OR POSSIBLE ACID SPLASH .

IGNITION TRANSFORMER PRODUCES HIGH VOLTAGE. ENSURE ALL ELECTRICAL POWER IS REMOVED WHEN WORKING ON THIS TRANSFORMER.

REPORTING ERRORS AND RECOMMENDING IMPROVEMENTS

You can help improve this manual. If you find any mistakes, or if you know of a way to improve the procedures, please let us know, Mail your letter, DA Form 2028 (Recommended Changes to Publications and Blank Forms), or DA Form 2028-2 located in back of this manual direct to: Commander, US Army Armament, Munitions and Chemical Command, ATTN: AMSMC-MAS, Rock Island, IL 61299-6000. A reply will be furnished to you.

Operator, Organizational, Direct Support and General Support Maintenance Manual Including Repair Parts List for:

Cleaner, Steam Pressure Jet
Skid Mounted
Model: RI 2400
(4940-00-186-0027)

NOTE

This manual is published for the purpose of identifying an authorized commercial manual for the use of the personnel to whom this equipment is issued.

Manufactured by: Jenny Division
Homestead Industries, Inc.
Box 348
Coraopolis, Pennsylvania 15108

Procured under Contract No. DAA09-84-C-8008

INSTRUCTIONS FOR REQUISITIONING PARTS
NOT IDENTIFIED BY NSN

When requisitioning parts not identified by National Stock Number, it is mandatory that the following information be furnished the supply officer.

- 1 - Manufacturer's Federal Supply Code Number - 29215
- 2 - Manufacturer's Part Number exactly as listed herein.
- 3 - Nomenclature exactly as listed herein, including dimensions, if necessary.
- 4 - Manufacturer's Model Number - RI 2400
- 5 - Manufacturer's Serial Number (End Item).
- 6 - Any other information such as Type, Frame Number, and Electrical Characteristics, if applicable.
- 7 - If DD Form 1348 is used, fill in all blocks except 4, 5, 6, and Remarks field in accordance with AR 725-50.

Complete Form as follows:

(a) In blocks 4, 5, 6, list manufacturer's Federal Supply Code Number - followed by a colon and manufacturer's Part Number for the repair part.

(b) Complete Remarks field as follows:

Noun: (nomenclature or repair part)
For: Model RI 2400 Cleaner, Steam Pressure Jet Skid Mounted
Manufacturer: Jenny Divisions
Homestead Industries, Inc.
Box 348
Coraopolis, Pennsylvania 15108
Model: RI 2400
Serial: (of end item)

Any other pertinent information such as Frame Number, Type Dimensions, etc.

TABLE OF CONTENTS

INDEX

1. DESCRIPTION
 - 1.1 Nomenclature
 - 1.2 Purpose and Function
 - 1.3 Dimensions
 - 1.4 Power Requirements
 - 1.5 Environmental Requirements
 - 1.6 Packing List
 - 1.7 Items Required For Operation
 - 1.8 Storage
 - 1.9 Tools
2. SAFETY PRECAUTIONS/WARNINGS
3. OPERATION
 - 3.1 Initial Start Up After Storage
 - 3.2 Start Unit - STEAM MODE
 - 3.3 Start Unit - PRESSURE MODE
 - 3.4 Stop Unit
 - 3.5 Change From 60 Hz. to 50 Hz.
 - 3.6 Change From 50 Hz. to 60 Hz.
 - 3.7 Operation Unit From Non-Pressurized Water Source
 - 3.8 Description of Operation and Components - ELECTRICAL
 - 3.9 Description of Operation and Components - WATER SYSTEM
 - 3.10 Description of Operation and Components - SOLUTION SYSTEM
 - 3.11 Description of Operation and Components - FUEL SYSTEM
 - 3.12 Description of Operation and Components - AIR SYSTEM
4. ROUTINE MAINTENANCE
PROCEDURE/FREQUENCY CHART
 - 4.1 Water System
 - 4.2 Fuel System
 - 4.3 Solution System
 - 4.4 Lubrication
 - 4.5 Mechanical
5. TROUBLE SHOOTING
 - 5.1 Water System
 - 5.2 Fuel System
 - 5.3 Solution System
 - 5.4 Electrical System
 - 5.5 Air System

1 DESCRIPTION

1.1 NOMENCLATURE

The RI 2400 is a skid mounted Combination Steam Cleaner and heated or cold Pressure Washer capable of heating 200 GPH to 350°F ±10°F in the STEAM MODE and 300 GPH at 400 psi to 180°F ±10°F in the PRESSURE MODE. The unit will operate in the PRESSURE MODE to produce 240 GPH - 400 psi spray at ambient water temperature. The RI 2400 can operate with or without cleaning compound.

1.2 PURPOSE AND FUNCTION

Unit is designed for cleaning of equipment. It will remove dirt, grease, oil and will decontaminate. Unit can be used with or without cleaning compound.

1.3 DIMENSIONS, WEIGHT, VOLUME, CENTER OF GRAVITY

LENGTH : 49.5 in 55.5 with liftfng/tie-down eyes
Width: 36.5 in 38.5 with hose and gun rack
HEIGHT: 55.5
HEIGHT: 1200 lbs. with gun, hoses, rack, cover - dry.
CENTER OF GRAVITY: See drawing number JP7223.

1.4 POWER AND WATER REQUIREMENTS

VOLTAGE: 230 V., 1 ph
FREQUENCY: 50/60 Hz.
CURRENT: 11 and Fuse 15 amp Slow Blow
WATER: 4 GPM @ 25 to 125 psi or un-pressurized water source
with an elevation no greater than 10 feet lower than unit.

1.5 ENVIRONMENTAL REQUIREMENTS

Continous electrical spark and open flame present during operation.
DO NOT operate in combustibile atomsphere or explosion will result.

1.5.1 Unit consumes oxygen during operation. Adequate fresh air must be provided during operation.

1.5.2 If unit is operated inside a building it must be vented to the outside. Open rain cap and install a 10 inch draft diverter and connect to a 10 inch class A flue.

1.5.3 If unit is operating in a heated room and vented to the outside during winter, a damper must be installed in flue and closed when unit is not in operation to prevent coil from freezing.

1.6 PACKING LIST

- 1 RI 2400 Cleaner
- 1 Suction Supply Hose - 1 inch ID x 35 feet with foot valve and coupling
- 1 Steam Hose 25 ft. long with coupling
- 1 Steam Hose 50 ft. long with coupling
- 1 Cleaning Wand with squeeze shut-off valve
- 1 Steam Blast Nozzle with orifice
- 1 2.inch Flat Steam Nozzle
- 1 4 inch Flat Steam Nozzle
- 1 Pressure Washer Tip
- 1 Pulley for 50 Hz. operation
- 2 Instruction Manuals
- 1 Inlet Water Hose 50 ft. 3/4 inch ID
- 1 Pack Fuse Plugs

1.7 ITEMS REQUIRED FOR OPERATION

POWER SOURCE: 230 V., 50/60 Hz., 1 ph (Fuse 15 amp Slow Blow.)

PLUG: To match power receptacle

WATER SOURCE: 25 to 125 psi 6 GPM minimum

1.8 STORAGE

1.8.1 Drain solution tank. Add 1 gallon anti-freeze (NSN 6850-00-644-1430) and 1 quart of water to solution tank.

1.8.2 Drain float tank using drain plug at bottom side of tank. Replace drain plug.

1.8.3 Remove fuse plug after water has stopped draining from unit, re-install fuse plug.

1.8.4 Fill float tank with anti-freeze mixture (75% NSN 6850-00-664-1430, 25% water) - approximately 3 gallons.

1.8.5 Connect unit to electric supply.

1.8.6 Place end of cleaning gun into float tank, open nozzle control valve on gun, hold open. Turn main power ON, set MODE switch for steam, turn pump ON. Before float tank empties add two additional gallons of 75% anti-freeze 25% water solution. This will permit anti-freeze/water solution to re-circulate thru unit.

1.8.7 After five (5) minutes of operation, close gun control to allow anti-freeze to flow thru the unloader by-pass line.

1.8.8 Open solution control valve wide to permit anti-freeze solution to flow thru solution lines and solution check valve.

1.8.9 Open gun and secure open with pump still operating (re-circulating anti-freeze solution) carefully "crack" (open slightly) the following fittings till solution comes out:

- A. Line connecting to PRESSURE switch (pressure switch end).
- B. Gauge connection at coil outlet.
- C. Gauge connection at coil inlet.
- D. Accumulator

1.8.10 Turn MODE switch to PRESSURE solution.

1.8.11 Remove gun from float tank and allow unit to operate until float tank is almost empty.

1.8.12 Turn pump OFF. Turn main power switch OFF.

1.8.13 Drain solution tank, drain float tank. Remove plug from left pump body, Using compressed air, blow into left pump body till all anti-freeze/water has been removed.

1.8.14 Remove, dry and re-install the following:

- A. Fuse plug (coil outlet)
- B. Accumulator (pump discharge)
- C. Y strainer (pump inlet)

1.8.15 Drain fuel system using drain plug at bottom of fuel tank. Disconnect fuel line at burner and turn unit ON and hold Blow-Down button in till fuel no longer comes out of fuel line (60 seconds maximum).

1.8.16 Remove oil filter then turn valve on top of filter to OFF position.

1.8.17 Re-connect fuel line removed in 1.8.15. Install new (dry) oil filter.

1.8.18 Release Tension on all belts:

- A. Jack Shaft drive belt by moving motor to right. Use holes on bottom of chassis channel to loosen "rear" (shaft end) motor bolts.
- B. Pump drive belt by moving pump to right.

1.9 TOOLS FOR MAINTENANCE, TEST, AND OPERATION

Normal hand tools including a small pipe wrench is all that will normally be required to maintain the RI 2400. Coil removal must be performed with the assistance of an overhead crane, block and tackle, fork lift or other rigging which will be capable of lifting heating coil (275 lbs) up and out of coil casing (approximately 10 feet high).

Electrical test can be performed with a volt/OHM meter and/or a continuity tester and test light.

3. OPERATION

3.1 INITIAL START-UP AFTER STORAGE/EXTENDED SHUT DOWN.

3.1.1. Remove from crate, remove hold down bolts from skids.

3.1.1.1 Check all hoses, lines and belts and wires for damage. Replace if necessary.

3.1.1.2 Adjust jack shaft belt tension by moving motor to left. Adjust water pump belt tension by moving pump to left.

3.1.1.3 Lubricate pump wrist pin with gear lube, G090 or equivalent.

3.1.1.4 Grease pillow block bearings (two) with grease, automotive and artillery (GAA), NSN 9150-00-190-0904 or equivalent.

3.1.2 Remove "Y" strainer from float tank outlet assembly. Clean and reinstall.

3.1.2.0.1 Remove strainer, (item 14, drawing JP7205-A) clean and reinstall.

3.1.2.1 Drain solution tank, drain oil tank (this will remove any moisture which condensed during storage).

3.1.3 Install cleaning hose and gun without spray tip and oriface.

3.1.3.1 Fill fuel tank with number 1 or number 2 diesel fuel. Turn valve on top of fuel filter ON. CAUTION: NEVER OPERATE UNIT WITH FUEL TANK EMPTY. THIS MAY RESULT IN PERMANENT DAMAGE TO FUEL PUMP.

3.1.4 Connect unit to water and electric supply source, fill solution tank with properly diluted cleaning compound, conforming to MIL-C-22542. For 5 gallons cleaning compound order NSN 6850-00-753-5000. If cleaning compound is not being used, fill solution tank with water.

3.1.5 Set MODE switch to pressure position. Turn main power switch ON. Open nozzle control, turn pump ON.

3.1.6 Allow water to flush thru unit for ten minutes. This will remove any sediment from the water system.

3.1.7 Turn unit OFF, follow procedure for steam or pressure operation below.

3.2 TO START UNIT-STEAM MODE

3.2.1 Install steam nozzle in cleaning gun, be certain steam orifice is screwed into the nozzle (ref. drawing JP7211).

3.2.2 Turn ON water supply connected to unit.

3.2.3 Turn MODE switch to STEAM position.

- 3.2.4 Open rain cap on coil.
 - 3.2.5 Open combustion air baffle to maximum position.
 - 3.2.6 Turn main power switch ON, turn pump switch ON.
 - 3.2.7 Squeeze gun handle and hold open till water flows from cleaning gun.
 - 3.2.8 Turn fuel switch ON.
 - 3.2.9 Adjust SOLUTION valve to percentage required.
- 3.3 TO START UNIT-PRESSURE MODE
- 3.3.1 Install pressure wash tip in cleaning gun.
 - 3.3.2 Turn on water supply connected to unit.
 - 3.3.3 Turn MODE switch to PRESSURE position.
 - 3.3.4 Open rain cap on coil.
 - 3.3.5 Close combustion air baffle to minimum position.
 - 3.3.6 Turn MAIN POWER switch ON, turn PUMP switch ON.
 - 3.3.7 Squeeze gun handle and hold open till water flows from cleaning gun.
 - 3.3.8 Turn fuel switch ON.
 - 3.3.9 Adjust SOLUTION valve to percentage required.
- 3.4 TO STOP UNIT
- 3.4.1 Turn SOLUTION valve OFF.
 - 3.4.2 Turn fuel switch OFF.
 - 3.4.3 Hold gun in the open position until outlet temperature is less than 100°F.
 - 3.4.4 Turn PUMP switch OFF, turn main power switch OFF.
 - 3.4.5 Close rain cap.
- 3.5 TO CHANGE FROM 60 HZ TO 50 HZ OPERATION
- 3.5.1 Disconnect unit from electrical power source.
 - 3.5.2 Loosen water pump mounting bolts, slide pump to right to release belt tension.

3.5.3 Loosen motor mounting bolts, slide motor to right to release belt tension.

3.5.4 Remove belts from motor pulley. Remove pulley.

3.5.5 Clean 50 Hz pulley, coat motor shaft with anti-seize compound, for example, NSN 8030-00-902-5514 or 8030-00-180-6187 and install 50 Hz pulley wide groove out (water pump pulley).

3.5.6 Install belts on motor pulley--blower belt first, then pump belt.

3.5.7 Tension blower belt by moving motor to left, then tighten motor mounting bolts.

3.5.8 Tighten water pump belt by moving water pump to left, tighten bolts.

3.5.9 Grease pulley removed from motor to prevent rust and install on stud provided. Secure with nut.

3.6 TO CHANGE FROM 50 HZ TO 60 HZ OPERATION

3.6.1 Disconnect unit from electrical power source.

3.6.2 Loosen water pump mounting bolts, slide pump to the right to release belt tension.

3.6.3 Loosen motor mounting bolts, slide motor to right to release bolt tension.

3.6.4 Remove belts from motor pulley. Remove pulley.

3.6.5 Clean 60 Hz pulley, coat motor shaft with anti-seize compound and install 60 Hz pulley wide groove out (water. pump pulley).

3.6.6 Install belts on motor pulley--blower belt first, then pump belt.

3.6.7 Tension blower belt by moving motor to left, then tighten motor mounting bolts.

3.6.8 Tighten water pump belt by moving water pump to left, tighten bolts.

3.6.9 Lubricate pulley removed from motor to prevent rust and install on stud provided. Secure with nut.

3.7 TO OPERATE UNIT FROM NON-PRESSURIZED WATER SOURCE

3.7.1 With main power switch OFF, remove plug (item 4 drawing JP7205-A) from float tank.

3.7.2 Turn valve on float tank outlet fittings to OFF (handle perpendicular to fitting) position.

3.7.2.1 Remove cover.

3.7.3 Remove 3/4 inch pipe plug (item 16 drawing JP7205-A) from float tank outlet fitting assembly.

3.7.4 Install suction hose (with supplied foot valve installed) into Tee (item 17 drawing JP7205-A).

3.7.5 Place foot valve into water source. Protect from sand, mud or trash as much as possible.

3.7.6 Follow 3.1 and 3.2 or 3.3 as desired.

3.8 DESCRIPTION OF OPERATION AND COMPONENTS - ELECTRICAL REF. JP7200

3.8.1 Turn switch S-1 to the "ON" position. This will energize the machine power circuit.

3.8.2 Turn switch S-2 to the "ON" position. This will energize the motor M-1, the ignition transformer T-2 and it will drive the water pump, air blower fuel pump.

3.8.3 Pressure switch PS-2 connected to the pump outlet before the mechanical unloader U-1 is normally open, it will close at 100 psi.

3.8.4 Temperature control TC-1, which is located at the coil outlet, is normally closed and will open above 360°F.

3.8.5 Burner switch S-3 will open the fuel solenoid provided the pressure switch PS-2 and temperature control TC-1 are closed. If any of these switches open, it will reenergize the fuel solenoid and therefore terminate the burner operation. With all the above switches closed, the burner circuit will be energized thru the following procedure.

- a. Time delay relay TD-1 will be energized and relay coil R-1 will be energized thru the normally closed TD-1 contact, provided pressure switch PS-3 is closed. Pressure switch PS-3 is normally open and will close when there is sufficient air pressure in the air chamber.
- b. With relay coil R-1 energized, relay contacts R-1A closes and will energize the fuel solenoid valve SV-1.
- c. With satisfactory burner performance flame sensor FS-1 will close and will maintain the relay coil R-1 holding circuit.
- d. After 45 seconds, time delay relay TD-1 normally closed contact will open and with the flame sensor FS-1 contact closed, the burner circuit will remain energized. When flame sensor FS-1 opens, it will reenergize the burner circuit.
- e. To reset burner circuit and time delay relay TD-1, open and close burner switch S-3.

3.8.6 Mode switch S-4 is to select either the pressure wash or steam mode of operation. This switch energizes and deenergizes, solenoid valve SV-3 for water bypass and changes fuel pump outlet pressure.

3.8.7 Blow down switch S-5 will be used in conjunction with valve V-5 for blow down operation. This switch enables the operator to energize the burner circuit.

3.9 DESCRIPTION OF OPERATION AND COMPONENTS-WATER SYSTEM - REF.DRAWING JP7221

3.9.1 (Reference drawing JP7205-A) Water enters the unit thru a hose ferrule into the float tank. Water is drawn from the float tank through a strainer in the float tank, then thru a float tank SHUT-OFF valve and a "WYE" strainer to the pump where its pressure is increased substantially.

3.9.2 (Reference drawing JP7212) The pump is equipped with an accumulator, a device which absorbs hydraulic pulsations in the water system. The hose which connects the pump outlet with the coil inlet fittings is an alleviator hose - a special hose which also absorbs hydraulic pulsations. On the RI-2400 a solenoid valve is used on the left output side of the pump to return a fixed volume of water back to the float tank. The volume of water "dumped" in this fashion is determined by an orifice placed in the return line. The switch used to control this dumping is called the MODE SWITCH (S-4). In its pressure position, it permits the full pumped volume of water to pass through the COIL: when this switch is on the STEAM position, a measured volume of water returns to the float tank thus reducing the volume of water pumped thru the heating coil.

3.9.3 (Reference drawing JP7219) The discharge line from the pump connects to the inlet of the heating coil. Because the RI-2400 is equipped with nozzle control, an unloader, a pressure actuated valve, is also connected to the outlet of the pump. The unloader diverts the water from the pump back to the float tank when the cleaning gun is closed.

3.9.4 At the coil inlet there is a pressure drain/relief valve which will protect the coil and pump from a blocked cleaning gun. A coil inlet pressure gauge is also connected to the inlet fittings assembly.

3.9.5 Water passes thru the coil, where it is heated, and into the coil outlet fittings assembly which includes an outlet pressure gauge, outlet temperature gauge and the sensing bulb for the temperature control (TC-1).

3.9.6 The hose and cleaning gun are attached to the coil outlet fitting assembly. The cleaning gun can be fitted with either a pressure wash tip or a steam nozzle and orifice assembly. The tip and orifice restrict the flow of water thru the system and cause the unit to operate at the correct pressure with the appropriate temperature rise. The cleaning gun handle is also equipped with a valve which will turn the cleaning spray on or off.

3.10 DESCRIPTION OF OPERATION AND COMPONENTS - SOLUTION SYSTEM

3.10.1 Cleaning solution is drawn from the stainless steel solution tank through the panel mounted solution valve, then into the right hand water pump body, through a ball check valve. This check valve prevents water from being pumped back into the solution tank.

3.11 DESCRIPTION OF OPERATION AND COMPONENTS - FUEL SYSTEM- REF.DRAWING JP7225

3.11.1 Number 1 or 2 diesel fuel, is placed in the fuel tank. Fuel is drawn out of tank thru a fuel filter by the fuel pump. The fuel filter holder is equipped with a shut-off valve. The dual pressure, shaft driven pump has a adjustable by-pass which diverts part of its output back to the top of the fuel tank. Its high and low pressure output is selected by the MODE SWITCH.

3.11.2 The main discharge line from the fuel pump goes through a fuel solenoid valve (SV-1) to the burner. This solenoid will SHUT-OFF fuel to the burner when cleaning gun is closed. Fuel solenoid is activated by a pressure switch which is connected to the water system at the coil inlet.

3.11.3 The burner is equipped with a 90 degree fuel jet and strainer assembly. The fuel jet size along with fuel pump output pressure determines how much fuel is burned and the strainer minimizes jet clogging due to dirt in the fuel.

3.12 DESCRIPTION OF OPERATION AND COMPONENTS - AIR SYSTEM

3.12.1 The squirrel cage fan is mounted on one end of a belt driven jack shaft and draws air into unit. The blower is equipped with an adjustable baffle to regulate the air supply if necessary.

3.12.2 Air is blown into a chamber under the coil casing and is forced thru the air whirler and through the burner assembly. The oxygen in the air supports the combustion of the oil and carries hot gasses through the heating coil thus transferring heat energy to the water passing through the coil.

3.12.2 A pressure switch (PS-3) will interrupt the flow of fuel to the burner if the fan would fail.

4 ROUTINE MAINTENANCE

MAINTENANCE PROCEDURE	FREQUENCY Hrs. of OPERATION	REFERENCE
WATER SYSTEM		4.1
Filter screen in float tank.	40	4.1.2
Y strainer-pump inlet.	40	4.1.3
Check accumulator pre-charge level.	400	4.1.4
Check alleviator hose-check to see if pliable.	400	4.1.5
Blow Down	8 hrs. or whenever inlet and outlet gauge shows a 60 psi pressure difference.	4.1.7
Chemical Descaling	40 hrs or if Blow Down fails to reduce pressure difference across the coil to 60 psi or less.	4.1.8
FUEL SYSTEM		4.2
Drain fuel tank/clean tank inlet strainer.	400 or sooner if fuel supply might be contaminated with water and/or dirt.	4.2.1
Change fuel filter.	200	4.2.2
Clean burner assembly.	8	4.2.3
SOLUTION SYSTEM		4.3
Drain solution tank & flush with water.	200	4.3.1
LUBRICATION		4.4
Oil wrist pin cavity	40	4.4.1
Grease pillow block bearing.	20	4.4.1

MAINTENANCE PROCEDURE	FREQUENCY Hrs. of OPERATION	REFERENCE
MECHANICAL		4.5
Tension belt	DAILY	4.5.1
Hoses	40	4.5.2
Nuts and bolts and set screws.	200	4.5.3

4.1.2 Filter screen in float tank (reference drawing JP7205-A) the filter screen or strainer (item 14) can be removed for cleaning by reaching under float tank baffle (item 23) and pulling it from the brass bushing (item 20). After cleaning, push strainer back into bushing.

4.1.3 Y strainer (reference drawing JP7205-A) (item 15) can be cleaned by removing cap and sliding strainer out of the fitting. Clean strainer and re-install.

4.1.4 Check accumulator pre-charge level.

The accumulator, has an air type valve and may be charged as show in sketch

Use regulator to set line pressure to 150 psi. Hold chuck on accumulator valve for 25 seconds (minimum) to insure accumulator has reach line pressure.

DO NOT charge accumulator with air.

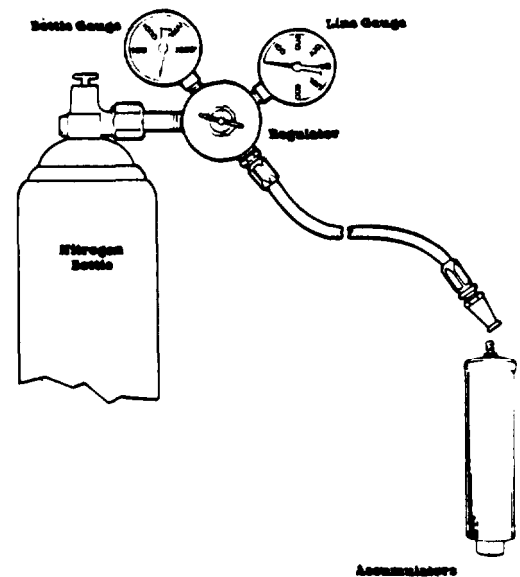

Check alleviator hose - hose which connects pump outlet to coil inlet fittings assembly.

4.1.5 With unit OFF and water system pressure released, the alleviator hose should be pliable enough to squeeze. If hose is stiff or shows signs of age it must be replaced.

4.1.7 Blow-Down

4.1.7.1 With unit OFF, remove steam hose from outlet fitting. Position machine so discharge from outlet will not spray on adjacent equipment or personnel, or be deflected back on to the unit.

4.1.7.2 Follow instructions 2 thru 6 to start---STEAM MODE.

4.1.7.3 Depress BLOW-DOWN button and hold in.

4.1.7.4 After outlet temperature reads 250°F, lift float rod (interrupting the flow of water through the unit) and hold for 1 minute after tank empties.

4.1.7.5 Release float rod and BLOW-DOWN button.

4.1.7.6 Allow unit to run till coil outlet temperature is 100°F ---- shut unit OFF.

4.1.7.7 Install steam hose in machine outlet.

4.1.8 Descaling Instructions.

4.1.8.1 Mineral deposits in the coil and coil outlet fittings assembly are the result of the affects of heat on un-dissolved solids in the water used. These deposits must be periodically removed to prevent the coil from being clogged.

4.1.8.2 Chemical descaling (deliming) should be attempted only after BLOW-DOWN procedure has failed to reduce the difference in coil inlet and outlet pressure to less than 60 psi.

4.1.8.3 Sulfamic Acid, NSN 6850-01-174-9548, comes in a 10 pound container and contains all inhibitors necessary to protect the metal parts of the equipment on which it is to be used.

4.1.8.4 Before the descaling procedures are started, read and follow all "DANGER", "WARNING", "CAUTION" and "FIRST AID STATEMENTS".

4.1.8.4.1 "DANGER"

Inhibited coil descaling powder contains "Sulfamic Acid" and is a poison and a corrosive chemical.

4.1.8.4.2 "DANGER"

"Sulfamic Acid" should not be handled unless the user is properly clothed, including rubber boots, rubber apron, rubber gloves and a full face shield. The user should read and understand the following procedure, along with the precautions printed on the acid container. "Failure to do so could result in severe or possible fatal injury to personnel."

4.1.8.4.3 "DANGER"

Operations must be done in a well ventilated area. Carbon dioxide vapors are released during this procedure. "Injury to personnel may result if proper ventilation is not provided."

4.1.8.4.4 "WARNING"

Do not handle sulfamic acid bare-handed. Moisture in the skin will activate the acid causing burns.

4.1.8.4.5 "FIRST AID PROCEDURES"

Sulfamic acid and its solutions can cause eye burns and may irritate the skin.

In cases of eye contact, immediately flush the eyes with plenty of water for at least 15 minutes. Call a physician.

For skin contact, flush with plenty of water.

For ingestion of sulfamic acid, immediately drink large amounts of water, "Do not Induce Vomiting". Call a physician.

4.1.8.4.6 Read the instructions on the sulfamic acid container before use.

4.1.8.4.7 "CAUTION"

Only authorized personnel who have read and understand this procedure should be permitted to perform this function.

4.1.8.5 Turn water supply ON.

4.1.8.6 Remove pressure wash tip and/or steam nozzle and orifice from cleaning gun. Place in float tank.

4.1.8.7 Clean "Y" strainer in float tank outlet assembly (item 15, drawing JP7205-A). Re-install.

4.1.8.7.1 Clean strainer in float tank (item 14, drawing JP7205-A).

4.1.8.8 Turn solution control valve to the OFF position (fully clockwise). Operate the unit in the PRESSURE MODE with the burner OFF for five minutes or until all cleaning compound has been purged from unit.

4.1.8.9 Turn water supply to the unit OFF and operate unit (FUEL OFF - PRESSURE MODE) nozzle control open - until after four (4) inches of water remains in the float tank. Place end of cleaning gun into float tank. This will cause water to re-circulate through unit. Secure gun (nozzle open) in this position. If water does not circulate, add water till it does.

4.1.8.10 To avoid nuisance clogging of the water reservoir strainer, it is recommended that a dished filter of steel or copper window screening be inserted on top of the water supply tank. The cleaning gun should be positioned to permit recirculation of water from the water supply tank through the cleaner, hose, cleaning gun, and back into the water supply tank through dished filter screen.

4.1.8.11 With the pump switch "ON" and the burner switch "OFF", allow the water to start recirculating through the cleaning gun and into the water reservoir.

4.1.8.11.1 "WARNING"

Do not allow the unit to produce steam with the cleaning solution circulating as injury to personnel may result from fumes or hot acid splash.

4.1.8.12 Pour approximately two pounds of sulfamic acid into the water reservoir tank. Turn on the water pump to circulate the solution. After thirty minutes, turn off the water pump and check the color of the solution. If a yellow color is present, the sulfamic acid is spent. If scale is still present in the heating coil, repeat the above adding 2 pounds of sulfamic acid at 30 minute intervals until the solution remains a reddish color for thirty minutes. During the above procedure cycle the burner (turn on and off) just long enough for the cleaning gun to feel warm but not hot. It may be necessary to stop cleaner from time to time to remove scale accumulation from dished filter screen and/or to pump excess solution into another container to avoid overflowing water supply tank. This excess solution must be subsequently neutralized using sodium hydroxide mixture outlined below. Turn off the water circulating system.

4.1.8.12.1 NOTE: Carbon dioxide is released as long as scale and sulfamic acid are present. After the scale is dissolved, gases cease to form and the color of the solution remains a reddish color.

4.1.8.13 Before draining the solution from the steam cleaner, it should be checked and neutralized as necessary. If a yellow color is present, the solution is spent and can be flushed into a sanitary sewer with equal parts of water. If the solution is a reddish color, it should be neutralized by adding Sodium Hydroxide (NSN 6310-00-270-8177, 13 oz). Turn on the water pump and slowly add enough sodium hydroxide to just change the color of the solution to a yellow color. When the solution just changes from red to yellow, it can be disposed of as outlined above.

4.1.8.14 STOP UNIT. Remove end of cleaning gun from float tank and place discharge end of gun in a drain or other location for disposal of solution.

4.1.8.15 Turn ON water to unit. Start unit and open nozzle control to flush water thru unit for ten minutes.

4.1.8.15.1 Flush with water any areas of unit splashed with acid.

4.1.8.16 Remove tips/nozzle from float tank.

4.1.8.17 Remove hose from coil outlet to allow sediment collected to flush out. Re-install hose.

- 4.1.8.18 Install pressure tip or steam nozzle in unit, set MODE switch and adjust air baffle appropriately.
- 4.1.8.19 Turn pump switch on, check coil inlet pressure gage with coil outlet pressure gage, if pressure differential is more than specified in the instruction manual, the coil may need a second treatment.
- 4.1.8.20 Fill solution tank with correctly diluted cleaning compound.
- 4.1.8.21 Unit is now ready for normal operation.
- 4.1.8.22 If a second treatment fails to reduce the pressure differential below the pressure specified in the instruction manual, the coil may need to be removed and soaked in a solution of sulfamic acid.
- 4.1.8.23 Coil soaking is an alternative to avoid the high cost of requisitioning a new coil. This can be performed by removing the coil from the cleaner and soaking the coil in a sulfamic acid solution of five pounds of sulfamic acid to five gallons of water. Enough solution should be mixed to completely cover the coil in a suitable container. Check the coil solution periodically for color. If the color of the solution is yellow, add two more pounds of sulfamic acid to the coil solution. Repeat as necessary until the solution stays a reddish color for at least 2 hours. This indicates very little scale is present.
- 4.1.8.24 Before draining the solution from the coil container, it should be checked and neutralized. Check the color of the solution, if the color is yellow, the solution can be disposed of into a sanitary sewer with equal parts of water. If the solution is red in color, add sodium hydroxide slowly until the solution just begins to change from red to yellow. When this change occurs, the solution may be flushed into a sanitary sewer with equal parts of water. Rinse the coil with water for five minutes and pour the neutralized solution down the drain, Reinstall the coil and test for leaks.

THIS PAGE LEFT INTENTIONALLY BLANK.

4.2 FUEL SYSTEM

4.2.1 Drain and clean fuel tank (ref. drawing JP7110) this procedure will waste a minimum of fuel if the fuel tank is almost empty prior to proceeding.

4.2.1.1 Follow 3.4 - to stop unit, remove drain plug (item 1, drawing JP7110) and permit fuel to drain completely from tank.

4.2.1.2 Clean fuel tank inlet strainer by removing cap and wiping strainer with a rag.

4.2.1.3 Replace drain plug (item 1, drawing JP7110) fill fuel tank with number 1 or number 2 diesel fuel.

4.2.2 Change fuel filter with unit OFF, Turn OFF fuel at filter holder (item 10, drawing JP7209-A).

4.2.2.1 Un-screw filter cartridge and discard. Lubricate gasket on top of new cartridge with oil and hand tighten.

4.2.2.2 Turn fuel ON at fuel filter holder (item 10, drawing JP7209-A).

4.2.3 Clean burner assembly.

4.2.3.1 With unit OFF, turn fuel filter valve to OFF position (item 10, drawing JP7209-A). DISCONNECT: Burner protector/skid plate, from chassis, high voltage lead from burner electrode two (2) wires to flame sensor (FS-1), and fuel line.

4.2.3.3 Wire brush electrodes - DO NOT wire brush burner jet or allow any dirt to enter orifice. Gap electrode to 3/23 inch.

4.2.3.8 Reversing procedure in 4.2.3.2 and making sure round" wire from high voltage transformer is connected to one of the two (2) burner mounting studs, tighten wing nuts to secure burner in place.

4.2.3.9 Reconnect; two (2) wires to flame sensor, fuel line, high voltage lead and re-install the burner protector shield.

4.2.3.10 Turn fuel filter valve to ON (item 10, drawing JP7209-A).

4.3 SOLUTION SYSTEM

4.3.1 Drain solution tank and flush with water. - With unit OFF, remove drain plug from side of tank.

4.3.1.1 After solution has drained from tank, remove tank cap and insert water hose into tank - push to the bottom. Turn ON water and flush for five (5) minutes.

4.3.2 Turn OFF water, remove hose and install drain plug removed in 4.3.1. Fill solution with compound conforming to MIL-C-22542.

4.3.2.1 If cleaning compound is not used, fill solution tank with water.

THIS PAGE LEFT INTENTIONALLY BLANK

4.4 LUBRICATION

4.4.1 Oil wrist cavity - Turn unit OFF. Using G090 fill cavity under felt washer at the water pump connecting rod. Note that the connecting rod has the word "OIL" cast into it with an arrow showing lubrication point (ref. drawing JP7212).

4.4.2 Grease pillow block bearings. Turn unit OFF. Using grease, automotive and artillery (GAA) lubricate using the zerk fitting on top of each of the two (2) pillow blocks. DO NOT OVER GREASE.

4.5 MECHANICAL

4.5.1 Belt tension - belt condition.

4.5.1.1 Visually examine belts for signs of wear and/or dry rot. If such evidence is found, belts should be replaced, retensioned and tension checked every 8 hours till belt (s) run-in (approximately 32 hours of operation). If replacement is required, refer to 6.5.1.

4.5.1.2 With unit disconnected from electrical power, push pump belt and jack shaft belt in turn, midway between the drive and driven pulleys. Belt deflection should be 0.125 inch.

4.5.1.3 If belts require adjustment, loosen the two pump mounting bolts (item a, drawing JP3245) and move pump to the right.

4.5.1.4 Loosen motor mounting bolts and slide to the left or right to properly tension the Jack Shaft Belt. DO NOT OVERTIGHTEN BELT.

4.5.1.5 Tighten motor mounting bolts. Slide pump (rail) to left until proper (water) pump belt tension is obtained. Tighten pump mounting bolts.

4.5.2 Hoses and fittings and clamps.

4.5.2.1 Visually examine all for signs of external wear, bubbles, or discoloration.

4.5.2.2 With unit OFF and water system released, squeeze hoses to determine if they are pliable (but not lifeless).

4.5.2.3 If any hose appears defective or shows signs of age during procedures 4.5.2.1 and 4.5.2.2, it must be replaced. If not replaced serious injury or death may result. See 2.1.6 and 2.1.7.

4.5.2.4 Examine fittings and clamps for signs of damage and/or leakage. Pay special attention to hose clamps. With unit OFF, tighten any fitting or clamp which is loose or leaking. Cleaning hose clamps should be tightened with machine running cold, bolts must be tightened only enough to stop leaking, DO NOT TIGHTEN ENOUGH TO DAMAGE HOSE. If clamps or fittings are determined to be defective, they must be replaced. If they are not, serious injury or death may result.

4.5.3 **Nuts, bolts, set screws.**

4.5.3.1 With unit disconnected from electrical power, check all visible nuts and bolts to be certain none are loose.

4.5.3.2 With allen wrench, check set screws on pump pulley, Jack Shaft pulley, fan hub and pillow block bearings. Pillow block bearings have 2 set screws. Tighten as necessary.

5 TROUBLE SHOOTING

5.1 WATER SYSTEM

<u>SYSTEM</u>	<u>POSSIBLE CAUSE</u>
5.1.1 Pump Operates. Water does not flow from cleaning gun.	<ul style="list-style-type: none"> a. Water source to unit off. b. Water not connected to unit. c. Float tank inlet valve stuck or clogged. d. Float tank outlet strainer clogged. e. Y strainer clogged. f. Float tank shut-off valve closed. g. Pump inlet check valve(s) stuck or defective. h. Nozzle control valve not open. i. Blocked tip in cleaning gun. j. Unloader valve stuck in by-pass MODE. k. Pump drive belt loose or missing. l. Pump outlet check valves stuck open. m. Coil outlet relief valve leaking.
5.1.2 Pump Operates, low water flow.	<ul style="list-style-type: none"> a. Float tank outlet strainer clogged. b. Water not connected to unit. c. One inlet and/or one outlet check valve stuck open or closed. d. Pump drive belt loose or missing. e. Blocked tip in cleaning gun. f. 60 Hz pulley on unit operating on 50 Hz. g. Coil outlet relief valve leaking. h. Air leak in suction lines. i. Cleaning solution valve open; solution tank empty.
5.1.2.1 Coil outlet relief valve leaks (drips).	<ul style="list-style-type: none"> a. Valve has dirt on seat. b. Valve not adjusted properly. c. Gun tip clogged

5.2 FUEL SYSTEM

5.2.1 Burner does not ignite (no fuel) (ref. also to 5.4.3, 5.4.0.1).	<ul style="list-style-type: none"> a. No fuel in tank. b. Fuel Shut-off valve (on filter) OFF. c. Clogged fuel filter. d. Soap/water in fuel tank. e. Burner jet clogged. f. Burner switch OFF. g. Fuel pump drive coupling broken (fuel pump not turning). h. Jack Shaft drive belt loose. i. Fuel solenoid not opening. j. Fuel line from tank plugged or kinked. k. Fuel line to burner kinked or plugged. l. Fuel pump is air locked. m. Pillow block or blocks seized up.
---	---

SYSTEM (continued)

POSSIBLE CAUSE

5.2.2 Burner does not ignite (fuel flows) (ref. also to 5.4.3, 5.4.0.1)

- a. Soap/water in fuel tank.
- b. Fuel pressure not properly adjusted.
- c. Air baffle not properly adjusted.
- d. Incorrect electrode gap.
- e. Transformer wire not connected to electrode.
- f. Ground wire not connected.
- g. Electrode cracked or damaged.
- h. Fuel burner spray not contacting electrode.

5.4 TROUBLE SHOOTING - ELECTRICAL SYSTEM

5.4.0.1 Burner does not light (also ref. to 5.2.1)

- a. No fuel (ref. to 5.4.1 and 5.4.1.5)
- b. No spark (refer to 5.4.2)
- c. Pump switch OFF.
- d. Motor overload button kicked out.
- e. Pump binding.
- f. Defective motor.
- g. Improper voltage.
- h. Front or back bearings seized.

5.4.0.3 Improper water volume on STEAM or PRESSURE MODE.

- a. Water pump solenoid (SV-3) stuck or defective. Dirt plugging orifice.
- b. MODE switch (S-4) defective or in wrong position.

5.4.0.4 Improper fuel pressure on STEAM or PRESSURE MODE.

- a. Fuel pump solenoid (SV-4) stuck or defective.
- b. Burner switch (S-4) stuck or in the wrong position.

5.4.0.5 Hour meter does work.

- a. Wire disconnected.
- b. Main power and pump switch not on.
- c. Meter defective.

5.4.0.6 Chassis electrically "HOT".

- a. Unit improperly grounded.
- b. Frayed current carrying conductor touching chassis.
- c. Improper connection to power source.
- d. Unit (or gun) in contact with live electrical power source.

5.4.1 If the fuel does not flow when switch is turned on, the following procedure should be followed to isolate possible component failure.

WARNING _ THESE PROCEDURES REQUIRE TESTS TO BE PERFORMED WITH PROTECTIVE COVERS OPEN OR REMOVED. THEY MUST BE PERFORMED BY PERSONNEL TRAINED TO MAKE ELECTRICAL REPAIRS.

5.4.1.1 Secure cleaning gun and have personnel hold in the "ON" position. Start unit following 3.3 with fuel on, place multi-meter across terminal 1 and 3. If 220 V is present, fuel solenoid is receiving power and is either defective or stuck.

5.4.1.1.1 To determine if coil is defective, remove coil from valve and insert screwdriver into coil. Turn burner switch ON. If coil is working screwdriver will be held in coil (no magnetic field present) and 5.4.1.1 indicated voltage to coil, coil is defective (or wire to coil is open).

5.4.1.2 If 220 V. is not indicated, one of the safety switches may be malfunctioning.

5.4.1.3 WARNING - DO NOT OPERATE THE UNIT WITH ANY OF THE SAFETY SWITCHES/ CONTROLS BYPASSED--INJURY OR DEATH MAY RESULT. ONCE FAULT IS ISOLATED, REPLACE SWITCH AND/OR RECTIFY CONDITION WHICH CAUSED SWITCH TO OPERATE.

5.4.1.4 In order to determine which safety switch is functioning/mal-functioning follow the procedure below IN THE ORDER WRITTEN.

Tip in gun.
 Water connected to unit/power connected to unit.
 Main power ON.
 Pump switch ON.
 Burner switch ON.

Operating voltage (220 vac) should be obtained between the following terminal strip locations. If voltage is not obtained, check function of the component listed at right. In order to quickly isolate problem, make voltage check in the order listed.

Terminal

1 - 2	S-2 Pump Switch
1 - 8	PS-2 Pressure Switch
1 - 7	TC-1 Thermo Control
1 - 4	S-3 Burner Switch
1 - 5	FS-1 Flame Switch
2 - 6	PS-3 Air Differential

Turn MODE Switch to STEAM

1 - 9	S-4 Mode Switch
-------	-----------------

5.4.1.5 In order to check FS-1 flame switch and TD-1 time delay relay for proper operation follow this procedure:

1. Connect water/power to unit.
2. Turn main switch OFF.
3. Disconnect (white) lead from FS-1 connected to terminal number 5 (ref. JP7201-A) - Insulate end of this wire -
4. Connect volt meter (240 Vac) across terminal 1 and 5. Turn ON main power switch. Turn pump switch ON.
5. When burner switch is turned on 220 volts should read for 45 seconds (between terminal 1 and 5).
6. After 45 seconds, voltage should drop to 0.
7. If initial voltage is 0 (and assuming PS-2, TC-1 and S-3 are functional) time delay (TD-1) is defective.
8. If after 45 seconds voltage (1 and 5) DOES NOT drop to 0 the time delay relay is defective.
9. With main power switch OFF, meter in OHMS MODE, check the resistance between the wire removed in step 3 and terminal 4. This should check open (infinite resistance) if shorted, flame sensor must be replaced.
10. If during normal operation the burner operates for 45 seconds and shuts off, the flame switch is not closing and it must be replaced.

5.4.2 No spark can be caused by:

- a. Faulty high voltage wire - replace.
- b. Damp transformer (arcking at transformer outlet) - dry transformer and wire.
- c. Defective transformer - replace.
- d. Improper burner spark gap - gap 3/32 to 1/8 inch.
- e. "Bridged" burner gap (most probable cause). Remove burner (ref.6.13), clean electrode.
- f. Cracked porcelain insulation on electrode - replace.
- g. Improper voltage - connect to correct voltage.

5.5 TROUBLE SHOOTING - AIR SYSTEM

5.5.1 Poor Combustion

- a. Rain cap closed.
- b. Air baffle on blower inlet improperly positioned.
- c. Jack Shaft drive belt/pulleys loose.
- d. Fan loose.
- e. Improper motor pulley installed for frequency of power supply.
- f. Insufficient oxygen in air supply.
- g. Missing air baffle in center of heating coil.
- h. Blockage in air chamber (chassis cavity).
- i. Hole in air chamber.
- j. Improper venting (restriction) of exhaust gas.
- k. Burner throat misshapen.
- l. Burner whirler blades bent.

6 REPAIR

6.1 INLET WATER SYSTEM

6.1.1 Float tank inlet fittings assembly (refer to drawing JP7205-A).

6.1.2 CAUTION - WHEN REPAIRING/REPLACING ANY INLET WATER FITTINGS/HOSES BE CERTAIN TO TIGHTEN COMPLETELY. IF NOT TIGHT, AIR WILL BE SUCKED INTO PUMP CAUSING A LOW WATER/HIGH TEMPERATURE CONDITION.

6.1.3 Strainer (item 14) is pressed into bushing (item 20) and can be easily removed by hand. Reach into float tank, slide strainer toward back of tank while rotating strainer slightly. Clean or replace strainer and re-install. DO NOT Re-install with machine running.

6.1.4 Y strainer (item 23) can be removed by removing cap (item 24) from strainer body (item 15). Clean or replace strainer - re-install in reverse order.

6.1.5 If necessary to replace float tank valve (item 7) remove float rod (item 6) and float prior to un-screwing float valve.

6.2 PUMP

6.2.1 Refer to drawings JP3245 and JP7212. Items likely to require servicing or replacement include:

- A. Inlet check valves (2) (item 16, drawing JP3245).
- B. Outlet check valves (2) (item 15, drawing JP3245).
- C. Pump crank shaft (item 21, drawing JP3245).
- D. Wrist pin (item 8, drawing JP3245).
- E. Pump piston (item 17, drawing JP3245).
- F. Pump pulley (item 8, drawing JP7212).
- G. Accumulator (item 13, drawing JP7212).
- H. Water pump solenoid (item 10, drawing JP7212).
- I. Tip (pump volume control) (item 11, drawing JP7212).
- J. Pump packing (item 14, drawing JP3245).

6.2.2 Inlet check valves. Remove hoses and using a box wrench, unscrew, remove and replace. CAUTION - inlet and outlet check valves have same thread size. Be certain to install check valves properly. Check valves are marked in and out. Inlet check valves are installed in bottom of pump bodies, outlet check valves on top of pump. Oil "O"Rings on check valves before installing.

6.2.3 Outlet check valves. (Refer to drawing JP7212)

6.2.3.1 To remove pump body outlet check valve:

- A. Remove coil from water pump solenoid (item 10).
- B. Remove pump hose from spud (item 15).
- C. Unscrew solenoid valve (item 10) and nipple (item 4).
- D. Disconnect copper tubing assembly (item 7) from elbow (item 1).
- E. Remove check valve and fittings - replace - re-install in reverse order.

6.2.3.2 To remove right pump body outlet check valve:

- A. Disconnect copper tube (item 7) from connector (item 2).
- B. Remove accumulator (item 13).
- c. Separate union (item 3).
- D. Remove check valve and fittings. Replace check valve and re-install in reverse order.

6.2.3.3 To remove pump and fittings assembly:

- A. Remove hoses from both pump inlet fittings (refer drawing JP7212).
- B.** Remove hose from water pump hose nipple (item 15).
- C. Remove water solenoid coil (item 10).
- D. Remove solution feed tube (item H).
- E. Disconnect pump outlet union (item 3).
- F. Loosen two bolts which hold pump rail to channel. Slide pump to right, remove pump drive belt.
- G. Remove bolts loosened in step F. Remove pump.

To re-install reverse above procedure.

6.2.4 To replace pump packing it is not necessary to completely disassemble pump (refer drawing JP3245).

6.2.4.1 Disconnect unit from power.

6.2.4.2 Rotate pump drive pulley till piston is with-drawn as far as possible from pump body to be worked on.

6.2.4.3 Un-screw packing nut (item 12) and slide back.

6.2.4.4 Dig out and discard old packing (item 14).

6.2.4.5 Unroll replacement packing and flatten slightly.

6.2.4.6 Work packing into cylinder by rotating pulley by hand allowing packing nut to push against packing. Install packing rings so splits are not aligned.

6.2.4.7 When last packing ring clears first thread on pump body (item 19 or 20) screw nut in tightly to compress packing, then loosen nut 1/8 turn.

6.2.4.8 Repeat 6.2.4.2 thru 6.2.4.7 for other pump body if necessary.

6.2.4.9 Turn pump by hand to be certain piston (item 17) DOES NOT BIND.

6.2.4.10 Connect unit to power, turn main power ON, turn pump ON. If water leaks out of packing, turn pump OFF and tighten packing nut. A slight weeping is preferable to packing nuts being too tight.

6.3 UNLOADER - R & R (REFER TO DRAWING JP7219)

6.3.1 Remove copper tubing from item 5 & 6 coil inlet fittings assy.

6.3.2 Disconnect alleviator hose coupling (item 3 drawing JP7212) then remove other end from tee (item 10 drawing JP7219).

6.3.3 Remove tee and attached fittings from unloader (item 10).

6.3.4 Remove hose connected to nipple at top of unloader (item 11).

6.3.5 Unscrew unloader (item 9) and/or check valve and adaptor (items 2,7,8) as required.

6.3.6 Replace unloader and/or check valve as required, re-assemble in reverse order.

6.4 OUTLET FITTINGS ASSEMBLY (REFER TO DRAWING JP7231)

6.4.1 Remove bonnet (stem assy. from outlet pressure relief valve (item 14).

6.4.2 Remove temperature gauge and temperature control sensing bulbs from fittings (item 12).

6.4.3 Remove outlet pressure gauge tubing line from item 11

6.4.4 Remove any other fittings necessary to provide clearance to unscrew remaining vapor outlet fittings at the cross (item 12) screwed into the stele (item 4).

6.5 COIL REMOVAL

6.5.1 Refer drawing JP7219 - Remove coil inlet fittings (6.3 thru 6.3.5) - Remove items 3, 14, 13 and 1.

6.5.2 Refer drawing Jp7231 - Remove coil outlet fittings (6.4 thru 6.4.4) - Remove item 16 coil outlet nipple.

6.5.3 Remove coil casing ring with rain cap attached.

6.5.4 Remove two bolts which secure top of coil to coil casing.

6.5.5 Connect chain or lifting strap to lifting/support bracket in center of coil - coil weighs approximately 275 lbs. - be certain lifting strap/chain is rated for at least 500 lbs.

6.5.6 Using an overhead crane, block and tackle, hoist or rigging device lift the coil straight up and out of unit.

6.5.7 Either move coil away from unit and set down, or slide machine out from under coil.

6.5.8 Fire pot will stay in coil casing.

6.6 COIL INSULATION REMOVAL/REPLACEMENT

6.6.1 Remove coil (6.5 thru 6.5.7).

6.6.2 To remove coil installation, cut banding and remove (Ref. drawing SK-42-84). Carefully pull shroud away from coil and remove.

6.6.3 Reinstall coil insulation by reversing above procedure when applying banding to insulation, be certain not to crush filler insulation into space between coils as combustion characteristics might be adversely affected.

6.7 FIRE-POT REMOVAL

6.7.1 Remove coil (6.5 thru 6.5.7).

6.7.2 Remove burner.

6.7.3 Reach into coil casing and lift pot out.

6.7.4 To replace fire pot, install burner, slide fire pot over burner throat, center fire pot carefully, re-install coil.

6.8 CLEANING GUN (REFER TO DRAWING JP7211).

6.9 FUEL SYSTEM - REFER TO DRAWING JP7110

This drawing shows the fuel tank and fittings assembly including sight gauge, drain plug and outlet and return line fitting.

6.9.1 Fuel tank removal. Fuel tank is removed with solution tank as a unit.

6.9.2 Drain fuel tank using plug (item 1 drawing JP7110).

6.9.3 Disconnect copper fuel lines from tank (item 9 and 10 drawing JP7110).

6.9.4 Drain solution tank using plug on side. Disconnect solution line from tank.

6.9.5 Remove four (4) bolts from fuel/solution tank mounting flange - remove tank(s).

6.9.6 To re-install tank, reverse above procedure.

6.10 FUEL PUMP AND FITTINGS REMOVAL - REFER TO DRAWING JP7209-A

6.10.1 Drain fuel tank (see 6.9.2).

6.10.2 Disconnect three copper lines connected to fuel pump assembly (from item(s) 1 and 5).

6.10.3 Remove solenoid coil from fuel valve (item 9).

6.10.4 Remove two bolts which hold fuel pump to mounting bracket.

6.10.5 Remove fittings (items 1 thru 10) as necessary.

6.11 FUEL PUMP (PRESSURE) ADJUSTMENT - REFER TO DRAWING JP7209-D

6.11.1 The outlet temperature of the unit is a function of inlet water temperature and fuel pressure. The fuel pump used on this unit has two settings which function independently.

6.11.2 Steam fuel pressure adjustment.

6.11.2.1 The fuel pressure adjustment screw (item 1) is located on the side of the fuel pump. With the MODE switch in the STEAM position turn the screw clockwise to increase the fuel pressure to the burner, counter clockwise to decrease fuel pressure to burner. With 65°F. inlet water, a fuel pressure setting of approximately 260 psi (as read on panel gauge) should heat outlet water to 350°F.

6.11.2.2 CAUTION - MAKE FUEL ADJUSTMENTS SLOWLY TO AVOID OVERHEATING.

6.11.3 Pressure rinse fuel pressure adjustemnt.

6.11.3.1 With pressure tip in gun, MODE switch in PRESSURE position set fuel pressure using screw on top of fuel pump (item 2). Turning the screw clockwise will increase fuel pressure to the burner, turning the screw counter clockwise will decrease fuel pressure to the burner. A fuel pressure setting of 95 psi should, with incoming water of 65°F. produces an output temperature of 200°F.

6.11.3.2 CAUTION - MAKE ADJUSTMENTS SLOWLY TO PREVENT UNIT FROM OVER HEATING.

6.12 FUEL FILTER REMOVAL - (REF. DRAWING JP7209-A) . TURN MAIN POWER OFF.

6.12.1 Turn valve on top of fuel filter to OFF position (item 10).

6.12.2 Unscrew fuel filter, discard, install new fuel filter (item 10).

6.12.3 Turn fuel valve ON (item 10).

6.13 BURNER REMOVAL/REPAIR - (REF. TO DRAWING JP7222) - TURN MAIN POWER OFF.

6.13.1 Turn fuel OFF at fuel filter.

6.13.2 Disconnect fuel line from burner at anti-syphon fitting assembly.

6.13.3 Disconnect high voltage from electrodes (item 9) and disconnect two (2) wires connected to FLAME switch.

6.13.4 Remove burner protector guard and burner assembly by removing wing nuts holding both on to the bottom of the chassis. Be certain not to damage the grounding wire connected to the burner.

6.13.5 Burner jet assembly.

6.13.5.1 Using a box wrench on burner jet and pipe wrench on burner nipple, remove burner jet. (Refer to drawing JP7222) dis-assemble jet whirler and strainer.

6.13.5.2 Soak jet whirler and strainer in dry cleaning solvent, NSN 6850-00-664-5682, or 1,1,1 - Trichloroethane NSN 6810-00-292-9625, while burner jet/strainer, and (fuel.) whirler are soaking, scrape carbon from air whirler.

6.13.5.3 Re-assemble jet/whirler/strainer and install into burner nipple.

6.14 ELECTRICAL SYSTEM - REFER TO DRAWINGS JP7200, JP7201, JP7201-A, JP7203-B.

WARNING - MOST OF THE FOLLOWING ADJUSTMENTS MUST BE MADE WHILE POWER IS ON AND UNIT IS OPERATING. UNIT WILL BE OPERATED WITHOUT PROTECTIVE COVERS IN PLACE. DO NOT TOUCH ELECTRICAL WIRING AND DO NOT BECOME ENTANGLED IN MOVING APPARATUS.

6.14.1 Pressure switch adjustment. Remove cover over pressure switch adjusting screw (ref. drawing SK-41-84). With STEAM position and the gun held open, water supply connected to unit, turn main power switch ON.

6.14.1.1 Turn adjusting screw counter clockwise till it stops.

6.14.1.2 Turn adjusting screw clockwise three (3) turns.

6.14.1.3 Turn burner switch ON - turn adjusting screw on PRESSURE switch (item 1) counter clockwise till burner ignites, then turn counter clockwise an additional 1/16 turn.

6.14.2 Air differential switch adjustment. Remove cover from and locate adjustment screw on top of switch (ref. drawing SK-40-84).

6.14.2.1 Rotate screw counter clockwise till it stops.

- 6.14.2.2 a. Install pressure wash tip in gun.
 b. Turn main power switch ON.
 c. Turn pump switch ON.
 d. Set MODE switch to PRESSURE.
 e. Close air baffle on blower.
 f. Hold gun OPEN.

6.14.2.3 Turn burner switch ON. If burner does not ignite, turn burner switch OFF. Turn air switch adjusting screw clockwise 1/4 turn. Turn burner switch ON.

6.14.2.4 Repeat 6.14.2.3 until burner ignites, then turn adjusting screw clockwise an additional 1/4 turn.

6.14.3 Thermal control - (ref. drawing JP7223). Thermal control is factory set for a maximum of 360°F. DO NOT adjust this high stop. Outlet temperature can be reduced by turning thermal control dial to a lower setting, however, temperature will swing $\pm 10^\circ\text{F}$. from the selected (lower) temperature and un-satisfactory cleaning may result.

6.14.4 Wiring (ref. to drawing JP7200, JP7201, JP7201-A and JP7203-B). Wire #16 AWG-(26 strands/#30) 600 volt, 60°C vinyl insulation- (Jenny JD3871 Ref. P/N)

6.14.4.1 To repair wiring, be certain to work only when the unit has been disconnected from all electrical power.

6.14.4.2 Always replace wires with those of equal or greater and dielectric strength.

6.14.4.3 Never splice wires, always replace.

6.14.4.4 When replacing wires, be certain they are protected against mechanical damage and abrasion.

6.14.5 For detailed description of the operation and inter relation of electrical components (ref. to section 3.8 and 5.4.1).

6.14.6 Transformer - Test - Replacement

WARNING - HIGH VOLTAGE

These procedures require the electrical power to be disconnected - and performed by personnel trained to make high voltage electrical repairs.

6.14.6.1 Disconnect Electrical Power. Also turn circuit breaker S-1 to off position (Ref. Dwg. SK-8-85).

6.14.6.2 Open the cover of the Switch Panel. Locate cable "J" and the black and white wire of the cable and disconnect from Terminal No. 1 and No. 2.

6.14.6.3 Disconnect the high voltage cable "C" at the bottom of the Burner Assembly (Ref. Dwg. JP7222).

6.14.6.4 SECONDARY TEST

One lead from an OHM-Meter to the high voltage terminal and the 2nd lead from the OHM-Meter to transformer ground. The meter should read somewhat less than 13,500 OHMS. An infinite reading would indicate an open circuit of high voltage cable "C" or transformer. Replace high voltage cable and repeat the test. An infinite reading - replace transformer.

6.14.6.5 Transformer replacement.

6.14.6.5.1 Remove high voltage cable assembly from transformer.

6.14.6.5.2 Remove ground wire from transformer.

6.14.6.5.3 Disconnect transformer lead wire from No. 1 and No. 2 terminals in J-Box. Thread wire thru rear of J-Box Assembly.

6.14.6.5.4 Loosen and remove nuts holding transformer base plate to coil casing.

6.14.6.5.5 Remove transformer.

6.14.6.5.6 To replace transformer, reverse steps 6.14.6.5.1 thru 6.14.6.5.5.

6.15 MECHANICAL DRIVE SYSTEM

6.15.1 Fan/Blower Wheel removal.

6.15.1.1 Empty fuel tank.

6.15.1.2 Remove line to fuel pressure gauge.

6.15.1.3 Remove fuel line connecting to fuel filter.

6.15.1.4 Loosen motor bolts, loosen pump mounting bolts, slide pump then motor to right. Remove pump drive belt.

6.15.1.5 Remove Jack Shaft drive belt from motor pulley.

6.15.1.6 Remove fuel pump mounting bolts, remove fuel pump and coupling and (leaving wires connected) move pump out of the way.

6.15.1.7 Loosen set screw on blower hub, slide blower back on jackshaft till it hits jackshaft drive pulley.

6.15.1.8 Remove the four bolts which hold jackshaft bracket to mounting base.

6.15.1.9 Slide pillow block mounting base toward front of machine till blower can be removed from the end of jackshaft.

6.15.1.10 To reinstall blower, reverse above procedure (6.15.1.1 - 6.15.1.10). Always align pulleys to prevent premature belt wear. Loosen set screws on both motor pulley and jackshaft pulley. Check and adjust alignment between pump and motor pulley. Tighten motor pulley. Check and adjust alignment between motor and jackshaft pulleys. Tighten jackshaft pulley. If necessary retension belts as in 4.5.1.

6.15.2 Jack Shaft Drive belt Replacement.

6.15.2.1 Follow 6.15.1.1 thru 6.15.1.7 and 6.15.1.9.

6.15.2.2 Slide pillow block mounting base toward front of machine till drive belt can be slipped over blower wheel and removed.

6.15.2.3 Install new belt over blower wheel and reverse above procedure to re-assemble unit (6.15.2.1 - 6.15.2.2). Always align pulleys to prevent premature belt wear. Loosen set screws on both motor pulley and jackshaft pulley. Check and adjust alignment between pump and motor pulley. Tighten motor pulley. Check and adjust alignment between motor and jackshaft pulleys. Tighten jackshaft pulley. If necessary retension belts as in 4.5.1.

6.15.3 Pillow Block Bearing Replacement.

6.15.3.1 Follow 6.15.1.1 thru 6.15.1.7.

6.15.3.2 Loosen set screw (s) holding pillow block bearing (s) to jackshaft.

6.15.3.3 Slide pillow block (s) toward fuel pump mounting bracket till it comes off of the shaft.

6.15.3.4 To reinstall, reverse 6.15.3.1 thru 6.15.3.3. Always align pulleys to prevent premature belt wear. Loosen set screws on both motor pulley and jackshaft pulley. Check and adjust alignment between pump and motor pulley. Tighten motor pulley. Check and adjust alignment between motor and jackshaft pulleys. Tighten jackshaft pulley. If necessary retension belts as in 4.5.1.

THIS PAGE LEFT INTENTIONALLY BLANK

7

ILLUSTRATIONS AND REPLACEMENT PARTS LIST

* JP3245	Pump Assembly
* JP3248-E	Relief Valve
* JP7110	Fuel Tank Fittings Assembly
* JP7200	Electrical Schematic
JP7201	Control Panel Wiring Diagram-Electrical
* JP7201-A	External Component Wiring
* JP7203-B	Control Panel Box Assembly
* JP7204-A	Gauge Panel Fittings Assembly
* JP7205-A	Float Tank Fittings Assembly
* JP7209	Fuel System and Blower Assembly
* JP7209-A	Fuel Pump & Fittings Assembly
JP7209-D	Fuel Pump Adjustment
* JP7211	Gun Assembly
* JP7212	Pump & Fittings Assembly
* JP7219	Coil Inlet Fittings Assembly
JP7221	Water System Flow Diagram
* JP7222	Burner Assembly
* JP7223	Elevations
JP7225	Fuel System Flow Diagram
* JP7231	Vapor Outlet Fittings Assembly
* JP7238-A	Solution Tank & Fittings Assembly
SK-7-85	Switch Panel
* SK-8-85	Hose Assemblies Breakdown
* SK-9-85	Blower Housing Assembly
SK-40-84	Air Differential Switch
SK-41-84	Coil Inlet Pressure Switch
SK-42-84	Coil Assembly
* SK-45-84	Hose Assembly

* THESE DRAWINGS ARE ACCOMPANIED BY A PARTS BREAKDOWN

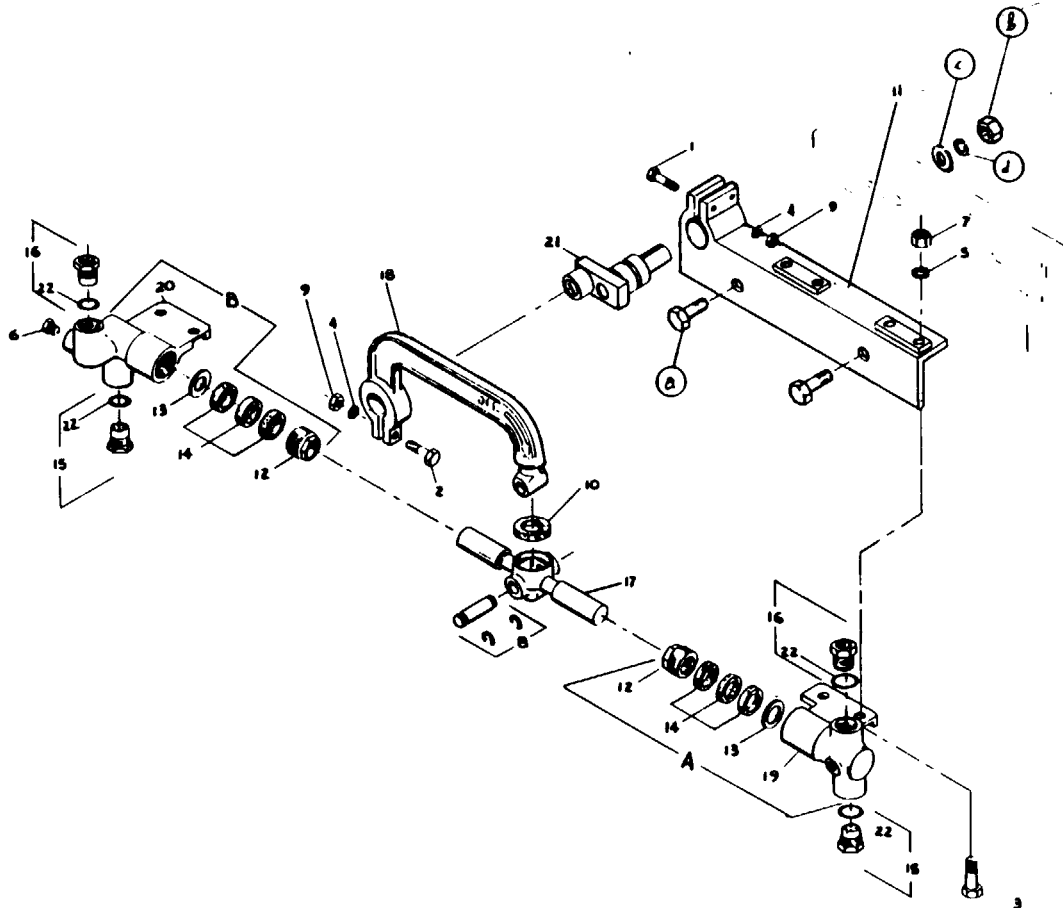

IT. NO	QTY	PART NO	DESCRIPTION
1	2	JD 536	SCREW, CP, NH, 5/16 x 2
2	1	JD 546	SCREW, CP, NH, 5/16 x 1 1/2
3	4	JD 573	SCREW, CP, NH, 1/2 x 1 1/2
4	3	JD 612	WASHER, LR, 5/16
5	4	JD 615	WASHER, LR, 1/2
6	1	JD 679	PLUG, 1/4
7	4	JD 983	NUT, 1/2
8	1	JD 2266	PIN ASSY
9	3	JE 755	NUT, 5/16
10	1	JL 197	WASHER, FELT
11	1	JL 204-03	PUMP RAIL
12	2	JP2603-04	NUT, PACKING
13	2	JP2603-07	RING, BACK UP
14	6	JP2603-Z	RING, PACKING
15	2	JP3208-A	INLET CHECK ASSY
16	2	JP3208-B	OUTLET CHECK ASSY
17	1	JP3247-01	PISTON ROD ASSY
18	1	JP3254-01	CONNECTING ROD
19	1	JP3279-01	PUMP BODY, R.H.
20	1	JP3280-01	PUMP BODY, L.H.
21	1	JP3879	CRANKSHAFT ASSY
22	4	JDS118	O-RING
A	(REF)	JP3236-B	PUMP BODY ASSY, R.H.
B	(REF)	JP3245-B	PUMP BODY ASSY, L.H.
a	(REF)	JD 568	SCREW, CR, NH, 1/8 x 1 1/2
b	(REF)	JD 792	NUT, 1/16
c	(REF)	JD 845	WASHER, RT, 1/16
d	(REF)	JD 848	WASHER, LA, 1/16

REV	WORK ORDER	DATE
TITLE PUMP ASSY 1300 C, 3100 R, 2400		
DATE	DR BY	APPROVED
SCALE	CHK	
DRAWN BY _____		CHECK & PRINT NO. JP3245

PUMP ASSEMBLY REF DRAWING JP3245

ITEM	QTY	DESCRIPTION	JENNY P/N	VENDOR	VENDOR P/N
1-22	1	Pump Assembly	JP3245		Note 1
1	2	Screw,CP,HH,S,2,BZ,5/16x2	JD 536	COML	Notes 2 and 3
2	1	Screw,CP,HH,S,2,BZ,5/16x 1-1/2	JD 546	COML	
3	4	Screw,CP,HH,S,2,BZ,1/2x1-3/4	JD 573	COML	
4	3	Washer, Lk,S,BZ,5/16	JD 612	COML	
5	4	Washer,Lk,S,BZ,1/2	JD 615	COML	
6	1	Plug,HS,S,1/4	JD 679	COML	
7	4	Nut,H,DC,F,S,BZ,1/2	JD 983	COML	
8	1	Wrist Pin with clips	JD2265	Jenny	Note 4
9	3	Nut,H,DC,F,S,BZ,5/16	JE 755	COML	
10	1	Washer, Felt	JL 197	Jenny	Note 5
11	1	Frame, Channel, Semi-Stl	JL 204-03	Jenny	
12	2	Nut,PK,BR,FG,1-3/4x1-9/64	JP2603-04	Jenny	Note 6
13	2	Ring, Solution Back-up	JP2603-07	Jenny	Note 7
14	6	Ring, Packing 1-1/8x3/8	JP2603-Z	Jenny	
15	2	Inlet Check Valve Assembly	JP3208-A	Jenny	Note 8
16	2	Outlet Check Valve Assembly	JP3208-B	Jenny	Note 9
17	1	Piston Rod	JP3247-01	Jenny	Note 10
18	1	Connecting Rod	JP3254-01	Jenny	Note 11
19	1	Pump Body, R.H.	JP3279-01	Jenny	Note 12
20	1	Pump Body, L.H.	JP3280-01	Jenny	Note 13
21	1	Crankshaft Assembly	JP3879	Jenny	Note 14
22	4	"O" Ring,7/8"x1-1/16"x3/32"	JD5118	COML	
A		Pump Body Assy. R.H.	JP3236-B	Jenny	
B		Pump Body Assy. L.H.	JP3245-B	Jenny	
a		Screw,CP,HH,S,2,BZ,7/16x1-1/2	JD 568	COML	
b		Nut,H,DC,F,S,BZ,7/16	JD 792	COML	
c		Washer, Ft,USS,S,BZ, 7/16	JD 845	COML	
d		Washer, 7/16, Lock	JD 848	COML	

Note 1 - NSN 4940-00-136-2257

Note 2 - BZ means Bright Zinc

Note 3 - NSN 5306-00-018-0087

Note 4 - NSN 4940-00-400-7167

Note 5 - NSN 4940-00-724-4351

Note 6 - NSN 4730-00-245-7724

Note 7 - NSN 5310-00-712-0393

Note 8 - NSN 4820-00-724-3732

Note 9 - NSN 4820-00-728-3734

Note 10 - NSN 4940-00-400-7176

Note 11 - NSN 4940-00-400-7178

Note 12 - NSN 4940-00-400-7173

Note 13 - NSN 4940-00-400-7172

Note 14 - NSN 4940-00-400-7177

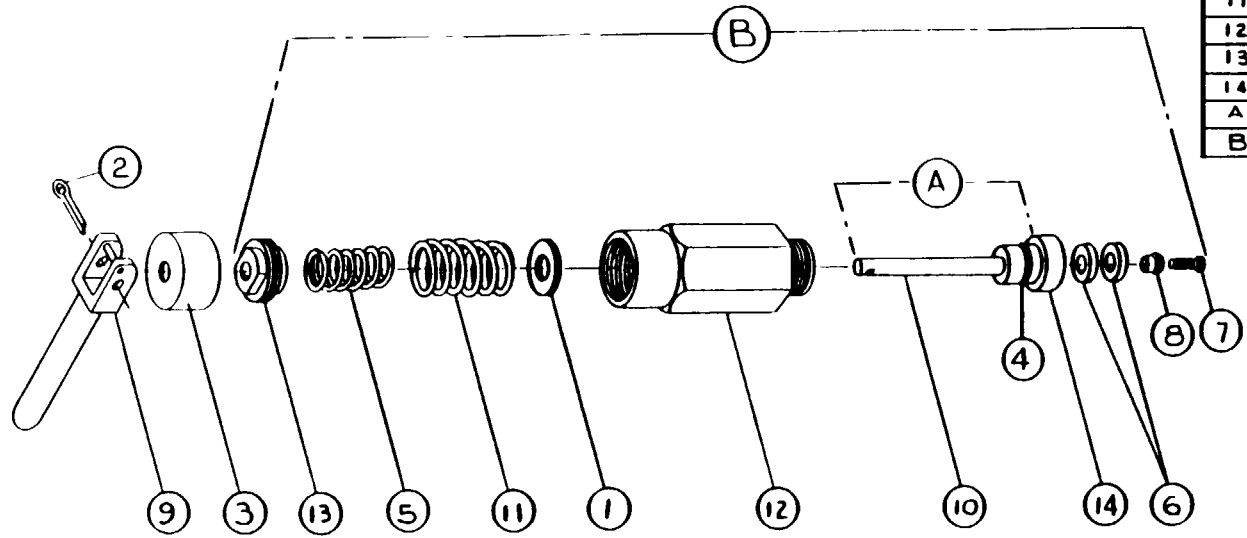

ITEM	QTY	PART NO	DESCRIPTION
1	1	JD 787	WASHER, FT. 1/4
2	1	JD1494	COTTER PIN
3	1	JD2839	CAP
4	1	JD5012	'O' RING
5	1	JP2687-03	SPRING
6	2	JP2687-04	WASHER, FIBRE BIBB
7	1	JP2687-09	SCREW / WASHER
8	1	JP2687-11	WASHER SHOULDER
9	1	JP2688-D	HANDLE / PIN ASSY.
10	1	JP2688-12	STEM ROD
11	1	JP3284-01	SPRING
12	1	JP3284-02	BONNET
13	1	JP3284-03	ADJUSTING NUT
14	1	JP3284-04	STEM BODY
A		JP3284-C	STEM BODY ASSY
B		JP2688-H	BONNET ASSY

CHG. NO.	REV.	DESCRIPTION	DATE

TITLE DRAIN & RELIEF VALVE R1 2400		
DATE 11-5-54	DR. BY [Signature]	PRINTED
SCALE 1/4"	CHK.	
		DWG. & PART NO. JP3284-E

TOLERANCE LIMITS UNLESS OTHERWISE NOTED
 ALL DIMENSIONS IN INCHES
 DECIMALS .005
 FRACTIONAL CASTING 1/16"
 SHEET METAL .015"
 OTHER .010"
 ANGLES 1/4"
 FILLETS .031" MAX ROUNDS .031" MAX
 ALL MACHINED SURFACES 12.5 MAX

RELIEF VALVE JP3284-E

ITEM	QTY	DESCRIPTION	JENNY P/N	VENDOR	VENDOR P/N
1	1	Washer, ft, USS,S, BZ, 1/4	JD 787	COML	Note 1
2	1	Pin,CT,S,BZ,1/8x3/4	JD1494	COML	Note 2
3	1	Cap	JD2839	Jenny	
4	1	Ring,O,B-N,3/8x1/2x1/16	JD5012	COML	Note 3
5	1	Spring	JP2687-03	Jenny	
6	2	Washer, Fibre Bibb	JP2687-04	Jenny	Note 4
7	1	Screw and Washer	JP2687-09	Jenny	
8	1	Washer, Shoulder	JP2687-11	Jenny	
9	1	Handle & Pin Assembly	JP2688-D	Jenny	
10	1	Stem Rod	JP2688-12	Jenny	
11	1	Spring	JP3284-01	Jenny	
12	1	Bonnet	JP3284-02	Jenny	
13	1	Adjusting Nut	JP3284-03	Jenny	
14	1	Stem Body	JP3284-04	Jenny	
A		Stem & Body Assembly	JP3284-C	Jenny	
B		Bonnet Assembly	JP2688-H	Jenny	

Note 1 - NSN 5310-00-655-7420

Note 2 - NSN 5315-00-839-5821

Note 3 - NSN 5330-00-981-7390

Note 4 - NSN 4820-00-803-6232

ITEM	QTY.	PART NO	DESCRIPTION
1	1	JD1339	PLUG, 'TRI-SURE', 3/4
2	2	JD2759	CLAMP, PLASTIC, 1/2 - 1/2
3	2	JD2917	ELBOW, 1/2 NPT x 3/8 TUBE
4	2	JD3068	CLAMP, 3/8
5	1.921	JD3087	TUBING, PV, 1/2 O.D. x 1/8 I.D.
6	1	JP7110-A	FUEL TANK ASSY
7	3	JD1032	BUSHING, 3/8 x 1/4
8	1	JD 990	BUSHING, 1/4 x 3/8
9	1	JD 652	ELBOW, 1/4-45 x 1/8 NPT
10	1	JD 653	ELBOW, 3/8-45 x 1/8 NPT
a	REF	JD 556	SCREW, CR, NH, 5/16 x 3/8
b	REF	JE 755	NUT, 5/16
c	REF.	JD 612	WASHER, LK, 5/16

- 1 JD1722-80 COPPER TUBING ASSY
- 1 JD1732-62 COPPER TUBING ASSY

THESE PARTS ARE FOR REF. ONLY AND ARE NOT INCLUDED WITH THIS R/M

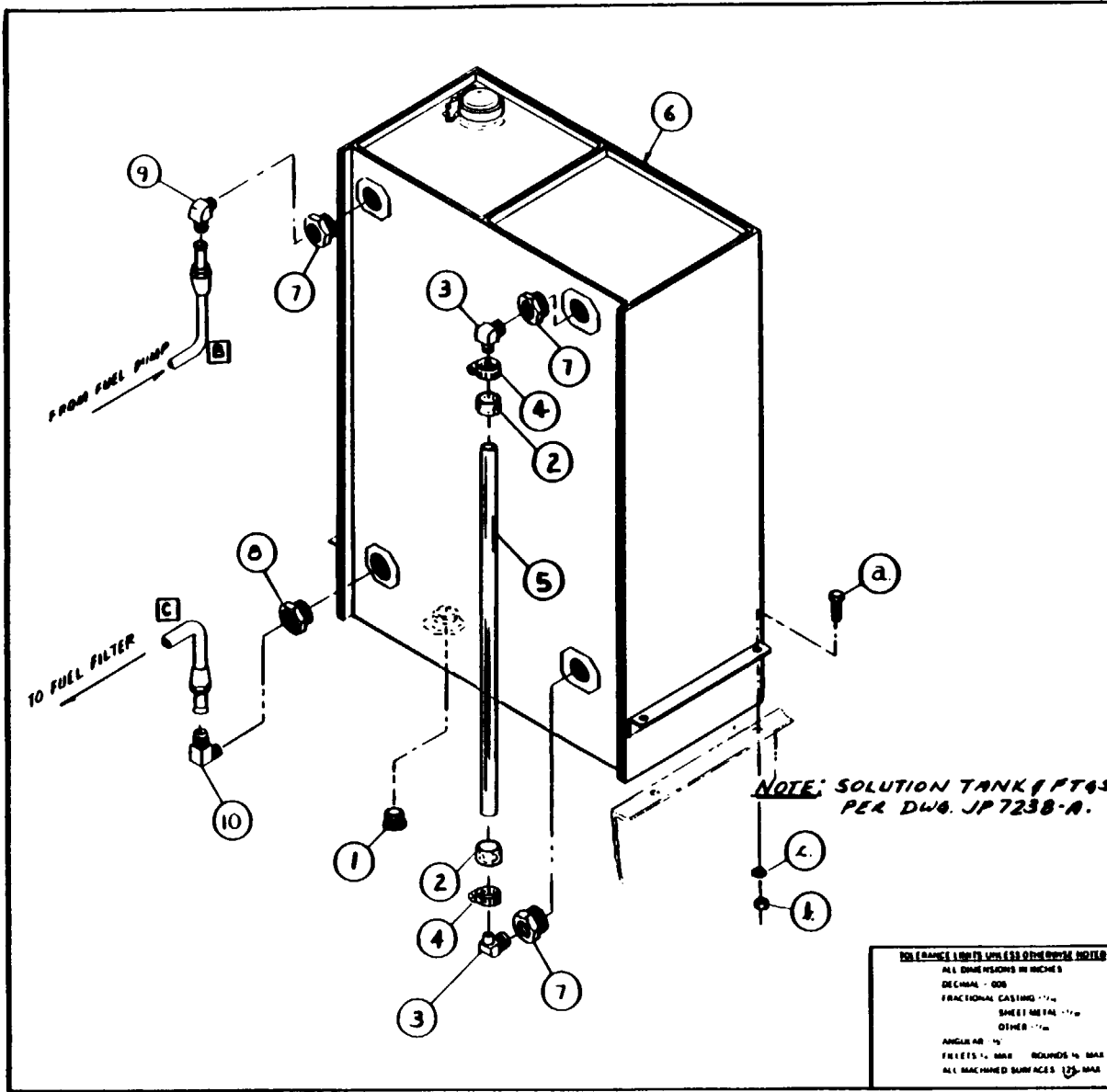

CHG. NO.	REV.	DESCRIPTION	DATE
5457	Δ		

TITLE		5457	
FUEL TANK FITTINGS ASSY.			
ROCK ISLAND 2400 O.E.S.			
DATE	DR. BY	PRINTED	
5-9-84	GL		
SCALE	CHK.		
1	J.K.		
		DWG. & PART NO.	
		JP7110	

FOR DIMENSIONS UNLESS OTHERWISE NOTED
 ALL DIMENSIONS IN INCHES
 DECIMAL - 0.05
 FRACTIONAL CASTING - 1/32
 SHEET METAL - 1/32
 OTHER - 1/64
 ANGLES 45°
 FILLETS 1/8" DIA. ROUNDS 1/8" DIA.
 ALL MACHINED SURFACES 125-1000

FUEL TANK FITTINGS ASSEMBLY JP7110

ITEM	QTY	DESCRIPTION	JENNY P/N	VENDOR	VENDOR P/N
1-10	1	Fuel Tank Fittings Assy	JP7110		
1	1	Plug, Stl.Pl't.w/Poly Gasket (TRI-SURE)	JD1339	AMER FLG	212000206
2	2	Clamp,Plastic, 1/2x1/2	JD2759	COML	
3	2	Elbow, 90,MB,BR,3/8x1/4NPTM	JD2917	COML	
4	2	Clamp, Hose,SS,7/32-5/8	JD3068	COML	
5	1.9	Tubing,PVC,3/8 ODx1/4NPTM	JD3087	COML	
6	1	Fuel Tank Assembly	JP7110-A	JENNY	
7	3	Bushing, 1/4 x 3/4	JD1032	COML	
8	1	Bushing,HX,150,MI,BK,3/4x3/8	JD 990	COML	
9	1	Elbow,90,BR,1/4-45x1/4NpTM	JD 652	COML	
10	1	Elbow,90,BR,3/8-45x1/4NPTM	JD 653	COML	
a	4	Screw,CP,HH,S,2,BZ,5/16x3/4	JD 556	COML	
b	4	Nut,H,DC,F,S,BZ,5/16	JE 755	COML	
c	4	Washer,Lk,s,BZ,5/16	JD 612	COML	
B	1	Copper Tubing Assembly 1/4" tubing x 80" long	JD1722-80	JENNY	
c	1	Copper Tubing Assembly 3/8" tubing x 62" long	JD1732-62	JENNY	

40

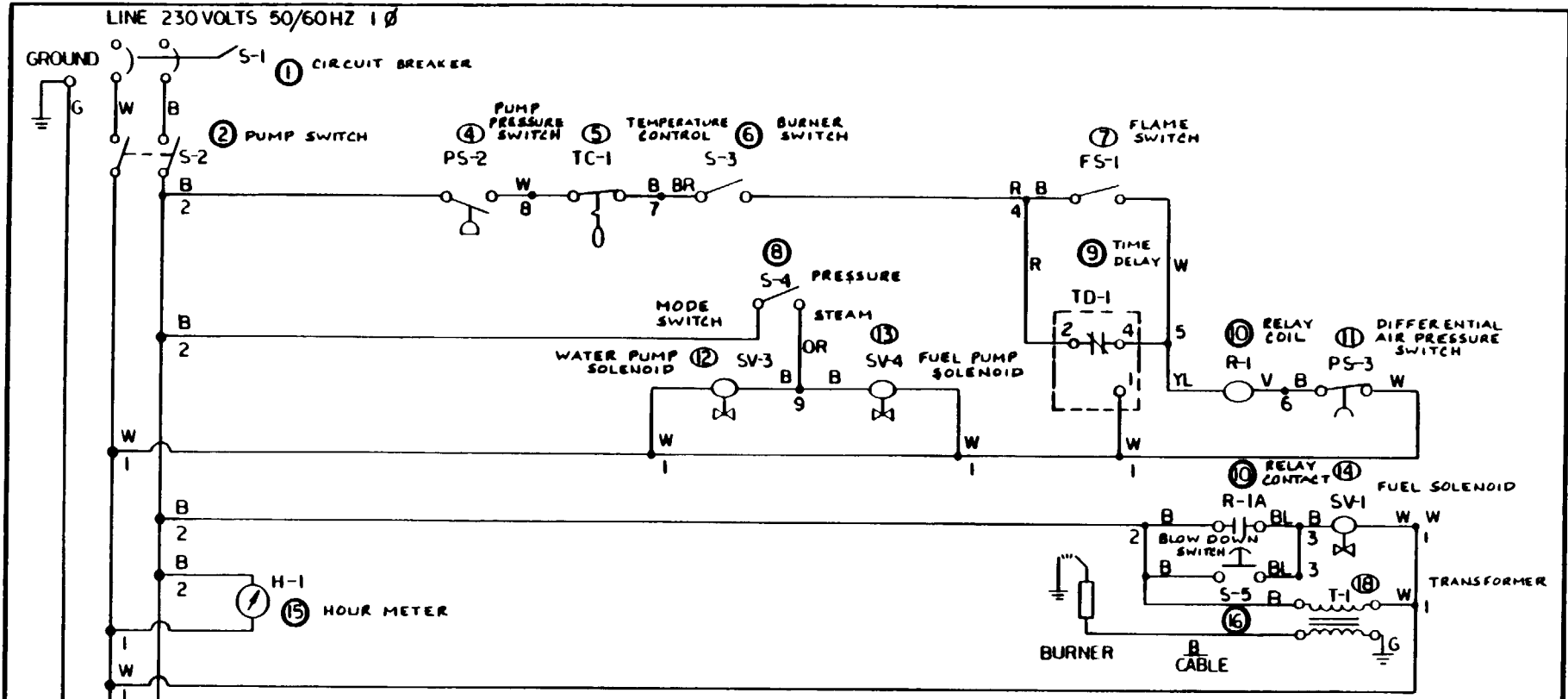

NOTES

- 1. ○ DOUBLE INDICATES PANEL MOUNT ITEMS
- 2. ITEM NUMBER PROVIDED TO IDENTIFY COMPONENTS
- 3. COLOR CODE: B-BLACK OR-ORANGE
 W-WHITE YL-YELLOW
 R-RED V-VIOLET
 BL-BLUE BR BROWN
 G-GREEN

5457	2	Names Added To Items	MJK
5457	1	GENERAL REVISION	MJK
CHG NO	REV	DESCRIPTION	DATE

TITLE			
ELECTRICAL SCHEMATIC			
ROCK ISLAND 2400			
DATE	DR BY	PRINTED	
5-26-84	MJK		
SCALE	CHK		
	JBL		
			DWG & PART NO.
			JP 7200

FOR BRANCH LOTS UNLESS OTHERWISE NOTED
 ALL DIMENSIONS IN INCHES
 DECIMALS - 1/32
 FRACTIONAL CASTING 1/16
 SHEET METAL 1/32
 OTHER 1/16
 HOLE DIA ± .005
 WALLS ± .015 ROUNDS ± .015
 ALL MACHINED SURFACES ± .015

ELECTRICAL SCHEMATIC - JP7200

ITEM	QTY	DESCRIPTION	JENNY P/N	VENDOR	VENDOR P/N
1	1	Circuit Breaker	JD7002	CARLING	AA2-B0-24-630-1B1-C
2	1	Switch, Toggle, 2PST	JD6168-04	CUTLER-HAMMER	7599K1
3	1	Power Cord, 14-3	JD6159	COML	
4	1	Pressure Switch	JD3415	BARKSDALE	96101-BB1- A
5	1	Temperature Control	JD3701-A	WHITE-RODGERS	11B06-31
6	1	Switch, SPST, Toggle	JD6168-01	MCGILL	3190-0003
7	1	Flame Switch Assembly	JP6162-B	JENNY	Essex Type 471
8	1	Switch, SPST, Toggle	JD6168-01	MCGILL	3190-0003
9	1	Relay, Time Delay	JD3152-B	OMNETICS	IMS-230-ALY45
10	1	Relay, 240Volts, 50/60 Hz	JP7115	NEWARK	20F767
11	1	Pressure Switch, Differential	JD6168	DWYER	1910-1-SPDT
12	1	Valve, Solenoid, Water Bypass	JD3063-A	ASCO	8223A23
13	1	Pump, Fuel, Two Stage	JP7116	SUNDSTRAND	B2TA-8851
14	1	Valve, Solenoid	JD1649-F	ASCO	8262D2 1V
15	1	Meter, Hour	JD2402-01	ENGLER	AC200-20NL7
16	1	Switch, Pushbutton, Electrical	JD6168-03	MCGILL	100-S
18	1	Ignition Transformer	JP3913-09	JENNY	
19	1	Motor, Electric, 1-1/2HP	JD3984-E	JENNY	

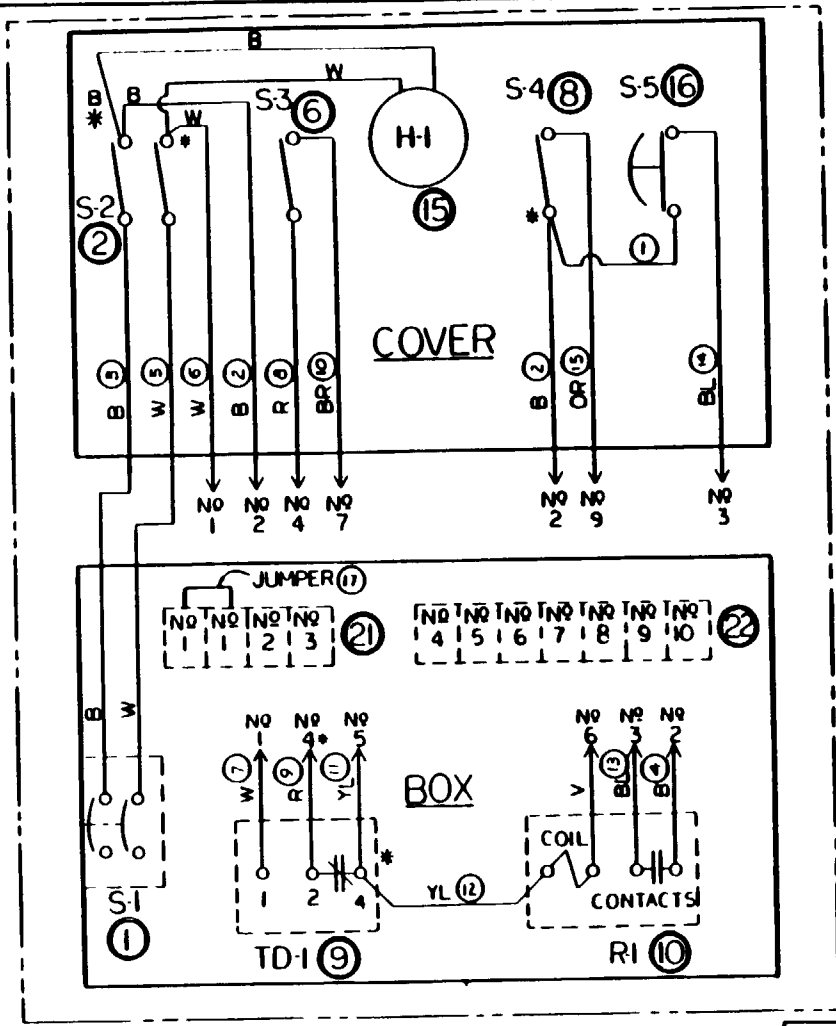

NOTES INDICATES PANEL MOUNTED ITEMS
 * PIGGY-BACK TERMINAL

COLOR CODE

- B - BLACK
- BR - BROWN
- BL - BLUE
- R - RED
- OR - ORANGE
- YL - YELLOW
- V - VIOLET
- G - GREEN
- W - WHITE

WIRE SET JP7240
 INDICATES ITEM NO ON WIRE SET

CHG NO	REV	DESCRIPTION	DATE
5457	2		
5457	1	REVISED - REDRAWN	

**TITLE CONTROL PANEL WIRING DIAGRAM
 ELECTRICAL SIDE (ROCK ISLAND 2400)**

DATE 7-11-54	DR. BY <i>GL</i>	PRINTED
SCALE <i>x</i>	CHK. <i>JGK/AT</i>	
		DWG & PART NO. JP 7201

TOLERANCE UNLESS OTHERWISE NOTED
 ALL DIMENSIONS IN INCHES
 DECIMALS .005
 FRACTIONAL CASTING .010
 SHEET METAL .015
 OTHER .010
 AMERICAN STANDARD
 PRACTICES TO BE OBSERVED
 ALL UNFINISHED SURFACES TO BE

THIS PAGE LEFT INTENTIONALLY BLANK

KEY

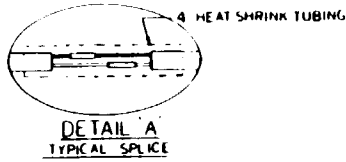
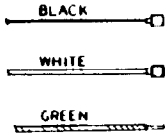

COMPONENT	JP 7200 DWG ITEM NO
FS 1	⑦
PS 2	④
PS 3	⑩
SV 1	⑩
SV 3	②
SV 4	③
T 1	⑨
TC 1	⑤

REF DWG'S

JP 7200	ELECTRICAL SCHEMATIC
JP 7201	WIRING DIAGRAM
JP 7203 B	CONTROL PANEL ASS'Y
JP 7239	WIRE SET

ITEM QTY	PART NO	DESCRIPTION
1	2	JU 3479 CONNECTOR
2	4	JU 3480 CONNECTOR CLIP
3	2	JU 4554 CONNECTOR
4	1	JU 48746 CONNECTOR
5	3	JU 435 WIRE NUT
6	1	JP1285-B CONNECTOR
7	4	JU 3555 WIRE NUT
8	3	JU 7007 TUBING H/SHRINK
9	1	JP7240-18 GROUND WIRE
A	1	JP7239-A CABLE ASSY
B	1	JP7239-B CABLE ASSY
C	1	JP7239-C CABLE ASSY
D	1	JP7239-D CABLE ASSY
E	1	JP7239-E CABLE ASSY
F	1	JP7239-F CABLE ASSY
G	1	JP7239-G CABLE ASSY
H	1	JP7239-H CABLE ASSY
J	1	JP7239-J CABLE ASSY
K	1	JP7239-K CABLE ASSY
L	1	JU 6159 POWER CORD

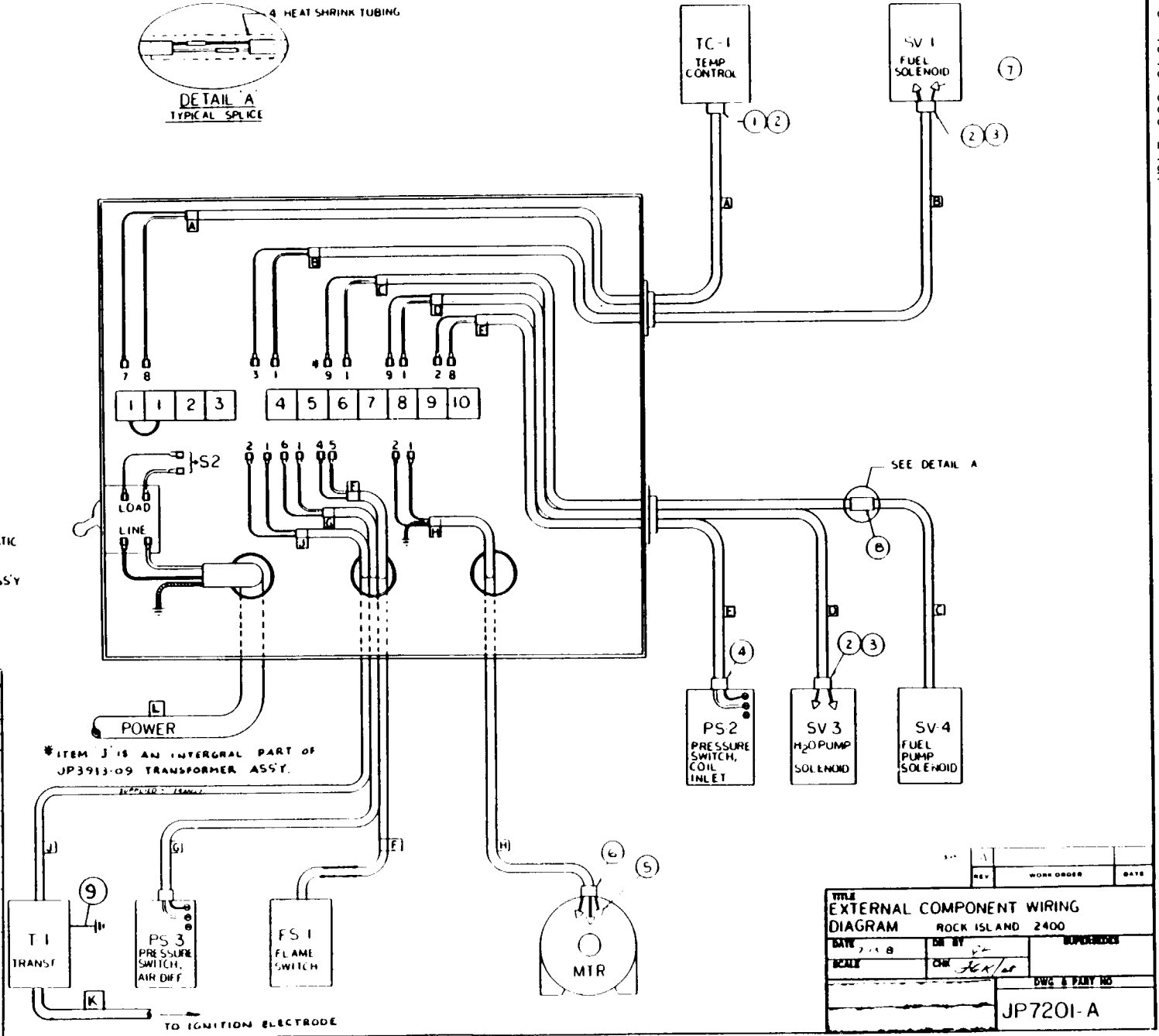

TITLE		WORK ORDER		DATE
EXTERNAL COMPONENT WIRING DIAGRAM		ROCK ISLAND 2400		
DATE	BY	REVISIONS		
SCALE	CHK	DWG & PART NO		
		JP7201-A		

EXTERNAL COMPONENT WIRING JP7201-A

ITEM	QTY	DESCRIPTION	JENNY P/N	VENDOR	VENDOR P/N
1	2	Bushing	JD3479	COML	
2	4	Adaptor, Anti-turn, Bushing	JD3480	COML	
3	2	Bushing, Heyco Str. Relief	JD1338	COML	
4	1	Connector, Crouse Hinds	JD1687-06	COML	
5	3	Wire Nut	JD1435	COML	
6	1	Connector	JP1285-B	COML	
7	4	Wire Nut	JD3555	COML	
8	.3'	Tubing H/Shrink	JD7007	COML	
9	1	Green Ground Wire 42"	JP7240-18	COML	Note #1
A	1	Cable Assembly 36"	JP7239-A	COML	Note #2
B	1	Cable Assembly 72"	JP7239-B	COML	"
C	1	Cable Assembly 58"	JP7239-C	COML	"
D	1	Cable Assembly 80"	JP7239-D	COML	"
E	1	Cable Assembly 36"	JP7239-E	COML	"
F	1	Cable Assembly 50"	JP7239-F	COML	"
G	1	Cable Assembly 24"	JP7239-G	COML	"
H	1	Cable Assembly 63"	JP7239-H	COML	Note #3
J	1	Cable Assembly			Note #4
K	1	Cable Assembly 42"	JP7239-K	COML	Note #5
L	1	Cable Assembly 75 Ft.	JD6159	COML	

- Note #1 - Green wire - #16 AWG (26 strands #30) vinyl insulation - 90° C - 600 Volt.
 Note #2 - Type SJO Cable (2 #18 AWG Wires, Black, White) 300 Volts - 60° C
 Note #3 - Type SO Cable (3 #14 AWG Wires, Black, White, Green), 300 Volts - 60° C.
 Note #4 - Cable is integral component of transformer JP3913-09.
 Note #5 - Type GTO-15 , #14-1 Polyetheylene, 1500 Volt.

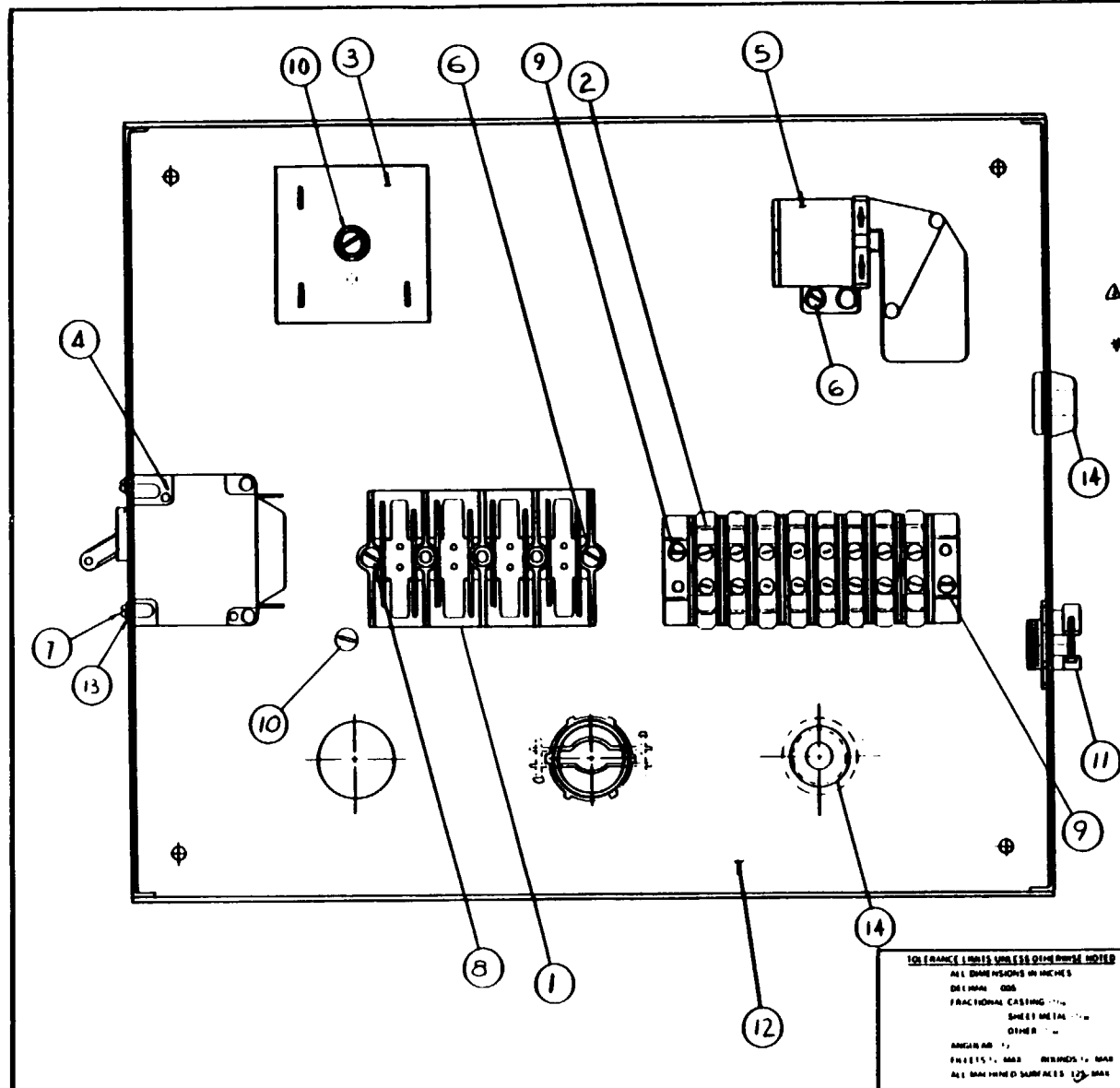

ITEM	QTY.	PART NO.	DESCRIPTION
1	1	JD2111-12	TERMINAL BLOCK
2	1	JD2111-13	TERMINAL BLOCK
3	1	JD3152-B	RELAY, TIME DELAY
4	1	JD7002	CIRCUIT BREAKER
5	1	JP1115	RELAY
6	2	JD3043	SCREW, STP # 8-32 x 3/8
7	4	.L&206	SCREW # 6-32 x 1/4
8	1	JD6188	SCREW, STP # 8-32 x 1/2
9	2	JD6189	SCREW, STP # 8-32 x 5/8
10	1	JD1207	SCREW, STP # 8-32 x 1
11	2	JP1205-B	CONNECTOR, BX
12	1	JP7203-D	JUNCTION BOX ASSY
13	4	JD 608	WASHER # 6 SK
14	2	JD3947	CONNECTOR, W/CO

* COMP 455 NOT SHOWN

5457	Δ	ADD: 3237	
5457	Δ		
5457	Δ	REV 6.000.00	
CHG NO	REV	DESCRIPTION	DATE

TITLE CONTROL PANEL BOX ASSY R.I. 2400		
DATE 10 7-54	DR BY GL	PRINTED
SCALE	CHK.	
		DWG. & PART NO. JP7203-B

TOLERANCE LIMITS UNLESS OTHERWISE NOTED
 ALL DIMENSIONS IN INCHES
 DECIMALS
 FRACTIONAL CASTING
 SHEET METAL
 OTHER
 ANGULAR 1:
 FINISH, S&S
 ALL MACHINED SURFACES 12.5 S&S

CONTROL PANEL BOX ASSEMBLY - JP7203-B

ITEM	QTY	DESCRIPTION	JENNY P/N	VENDOR	VENDOR P/N
1-14	1	Control Panel Box Assy.	JP7203-B	JENNY	
1	1	Terminal Block	JD2111-12	COML	
2	1	Terminal Block	JD2111-13	COML	
3	1	Relay, Time Delay	JD3152-B	OMNETICS	IMS-230ALY45
4	1	Circuit Breaker	JD7002	CARLING	AA2-80-24-630-1B1-C
5	1	Relay	JP7115	NEWARK	20F 767
6	2	Screw,STP,#8-32x3/8	JD3043	COML	
7	4	Screw,MC,#6-32x 1/4	JD6206	COML	
8	1	Screw,STP,#8-32x7/8	JD6188	COML	
9	2	Screw,STP,#8-32 x 5/8	JD6189	COML	
10	1	Screw,STP,#8-32 x 1	JD6209	COML	
11	2	Connector,Bx	JP1285-B	JENNY	
12	1	Junction Box Assy.	JP7203-D	JENNY	
13	4	Washer, #6, SK	JD 608	COML	
14	2	Connector, "Heyco"	JD3947	HEYMAN	SR-31-2

ITEM	QTY	PART NR	DESCRIPTION
1	2	JD 856	ELBOW 1/2 45° x 1/2 NPTM
2	3	JD1004	SCREW STD #10 x 3/8
3	2	JD3418	GAUGE PRESSURE
4	1	JD6160	GAUGE TEMP. REMOTE
5	1	JD7022	VALVE SOLUTION
6			
7	1	JP2732	GAUGE PRESSURE
8	1	JP7204	PANEL GAUGE
9	1	JP7204-01	DECAL GAUGE PANEL
10	1	JP7204-02	BRACKET SOLUTION VALVE
11	2	JD2391	CONNECTOR ST. 1/2 NPT x 1/2 45
a	REF	JD1019	SCREW STD #10 x 1/2 x 1/8
b	REF	JD7022-01	KNOB

- D 1 JD1722-68 COPPER TUBING ASSY
- E 1 JD1722-28 COPPER TUBING ASSY
- G 1 JD1722-25 COPPER TUBING ASSY
- H 1 JD1722-44 COPPER TUBING ASSY
- K 1 JD1722-31 COPPER TUBING ASSY

THESE PARTS ARE FOR REF ONLY AND ARE NOT INCLUDED WITH THIS B/M

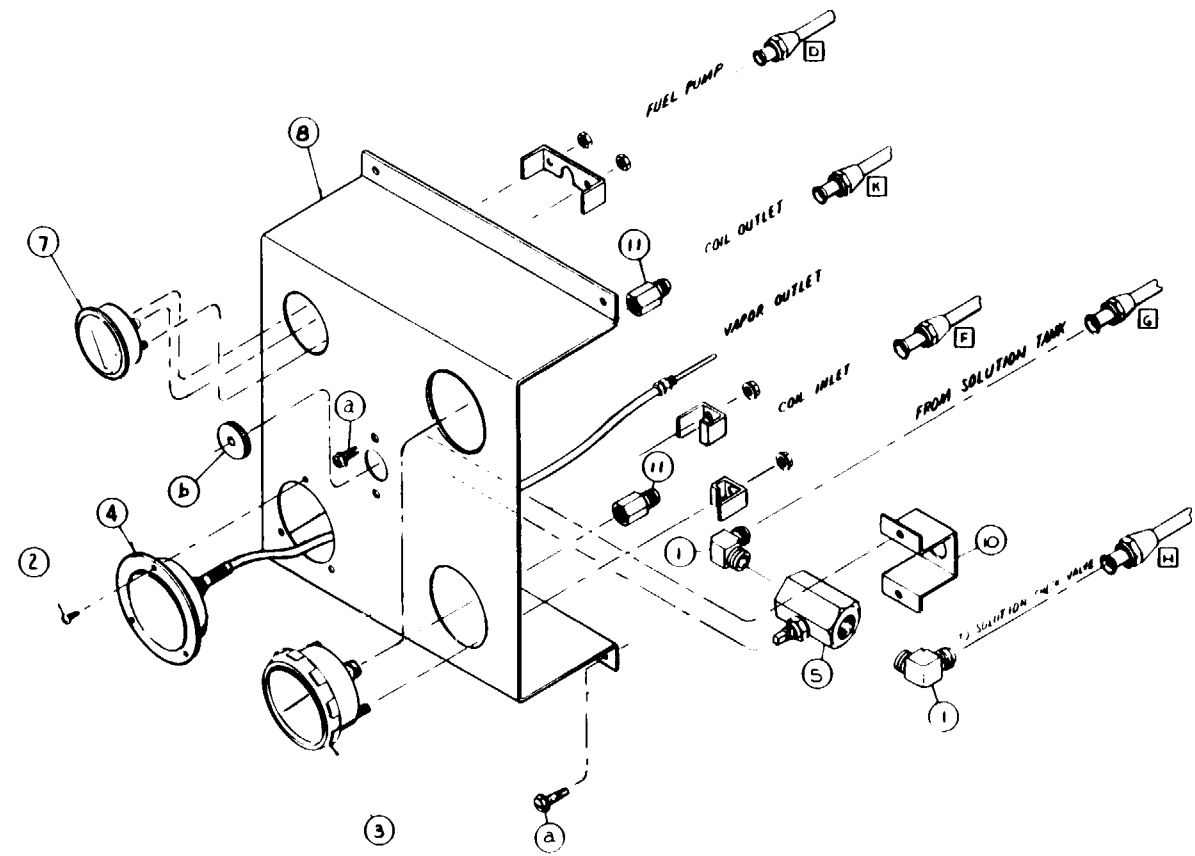

REV	DATE	BY	REASON
1			
2			
3			
4			
5			
6			
7			
8			
9			
10			
11			
12			
13			
14			
15			
16			
17			
18			
19			
20			
21			
22			
23			
24			
25			
26			
27			
28			
29			
30			
31			
32			
33			
34			
35			
36			
37			
38			
39			
40			
41			
42			
43			
44			
45			
46			
47			
48			
49			
50			

TITLE		
GAUGE PANEL FITTINGS ASSY		
RT 2400		
DATE	DR BY	REVISIONS
SCALE	CHK	
DRAWN & PART NO		
		JP7204-A

GAUGE PANEL FITTINGS ASSEMBLY - JP7204-A

ITEM	QTY	DESCRIPTION	JENNY P/N	VENDOR	VENDOR P/N
1-11	1	Gauge Panel Fittings Assy.	JP7204-A	JENNY	
1	2	Elbow, 1/4-45 x 1/4 NPTM	JD 652	COML	
2	3	Screw, STP, #8 x 3/8	JD3043	COML	
3	2	Pressure Gauge	JD3418	SPAN INST.	#LFP-224
4	1	Gauge, Temp. Remote	JD6160	THUMLING	401.01
5	1	Valve, Solution	JD7022	DELTROL	20BK
7	1	Pressure Gauge	JP2732	ROCHESTER	2552-00006
8	1	Panel, Gauge	JP7204	JENNY	
9	1	Decal, Gauge Panel	JP7204-01	JENNY	
10	1	Bracket, Solution Valve	JP7204-02	JENNY	
11	2	Connector, ST,1/4-NPTx1/4-45	JD2391	COML	
a	REF	Screw, Stp, #10-32x3/8	JD7019	COML	
b	REF	Knob, Solution Valve	JD7022-01	JENNY	
D	1	Copper Tubing Assy. 1/4" x 68" long	JD1722-68	COML	
F	1	Copper Tubing Assy. 1/4" x 28" long	JD1722-28	COML	
G	1	Copper Tubing Assy. 1/4" x 25" long	JD1722-25	COML	
H	1	Copper Tubing Assy. 1/4" x 44" long	JD1722-44	COML	
K	1	Copper Tubing Assy. 1/4" x 31" long	JD1722-31	COML	

ITEM QTY	PART NO	DESCRIPTION
1	1	JD800-01 ELL SF 1/2" BR
2		
3		
4	1	JD1339-01 PLUG 3/8" TRI-SURE 2/STL
5	1	JD146-01 BALL FLOAT
6	1	JD3001-01 ROD FLOAT
7	1	JD2988 VALVE FLOAT
8		
9	1	JD3094-02 NIPPLE 1/2" S. BR
10	2	JD3096 NIPPLE CL 1/2" BR
11	1	JD3096 BUSHING 1/2" S. BR
12		
13	1	JD3566-01 VALVE BALL 1/2" LHM 1/2" BZ
14	1	JD3843 STRAINER
15		
16	1	JD7000 PLUG PIPE 1/2" STL
17	1	JD7000-01 TEE SF 1/2" BR
18	1	JP635-A NUT NOSE
19	1	JP2126 FERRULE 1/2"
20	1	JP6594 BUSHING STRAINER BR
21	1	JP6736-A WATER TANK FTY
22	1	JP7205 FLOAT TANK ASSY
23	1	JD6161 Y STRAINER ASSY
23A	1	JD6161-01 ELEMENT
23B	1	JD6161-02 DISC
23C	1	JD6161-03 CAP
23D	1	JD6161-04 PLUG

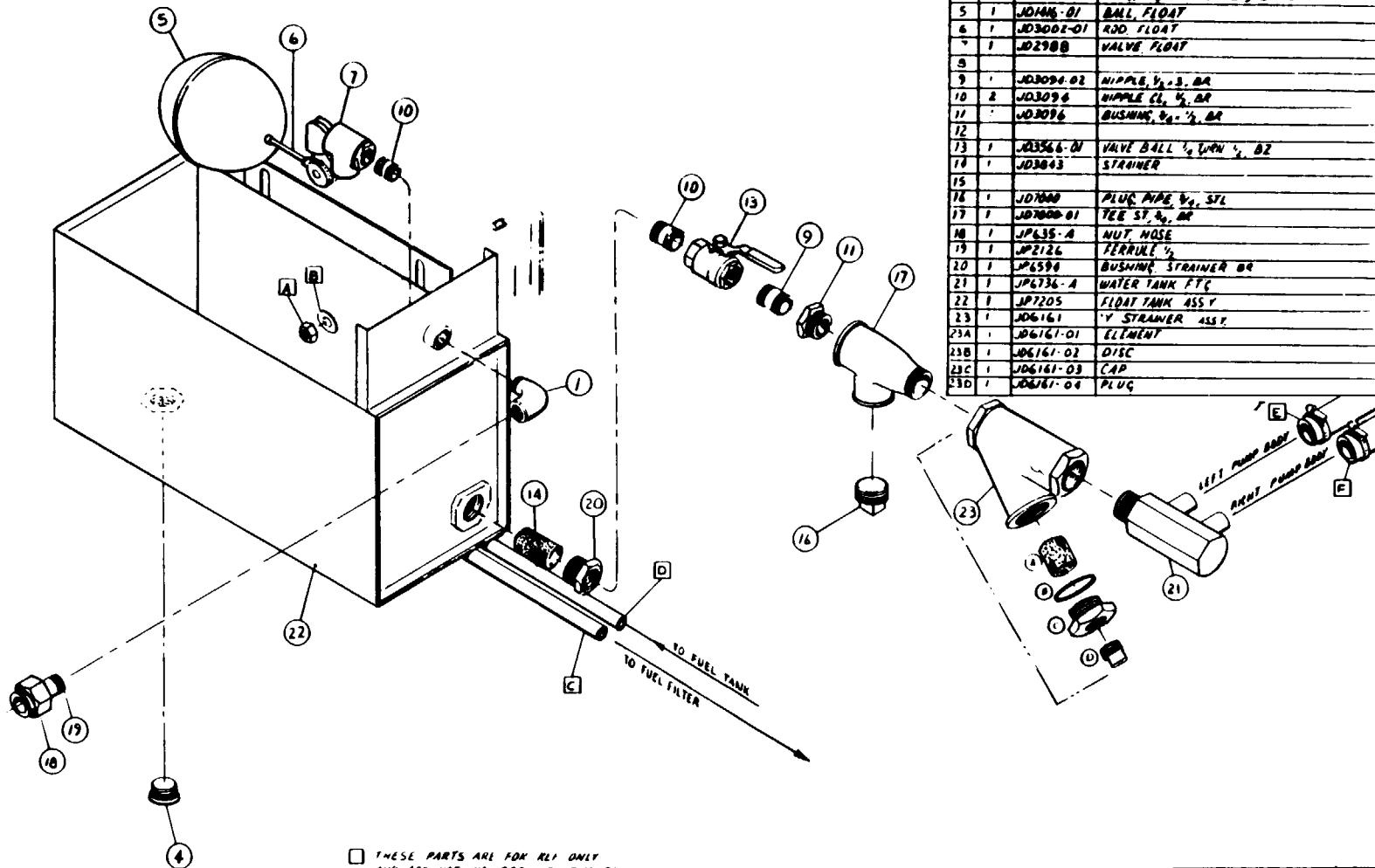

- ☐ THESE PARTS ARE FOR KLI ONLY AND ARE NOT INCLUDED WITH THIS B/M
- A JE 755 NUT, 8/16
 - B JD 894 WASHER FT, 8/16
 - C JD1732-62 COPPER TUBING ASSY
 - D JD1722-80 COPPER TUBING ASSY
 - E JL146-08 HOSE 3/8 I.D. x 8" LG.
 - F JL146-22 HOSE 3/8 I.D. x 22" LG.

3451	REV	ADD	DATE
3451	Δ
REV	DESCRIPTION	DATE	
TITLE FLOAT TANK FITTINGS ASSY ROCK ISLAND 2400			
DATE	7-6-84	DR BY	JK
SCALE	2	CHK	JK
DRAWING MADE BY CHECKED BY APPROVED BY FILED IN: 146-118-000-118-000 ALL DIMENSIONS UNLESS OTHERWISE SPECIFIED ALL DIMENSIONS IN INCHES		PART NO JP7205-A	

FLOAT TANK FITTINGS ASSEMBLY JP7205-A

ITEM	QTY	DESCRIPTION	JENNY P/N	VENDOR	VENDOR P/N
1-23	1	Float Tank Fittings Assy.	JP7205-A	JENNY	
1	1	Elbow,ST,90,150,BR,1/2	JD 800-01	COML	
4	1	Plug,Stl,Plt,w/Poly Gasket (TRI-SURE)	JD1339	AMER FLG	212000206
5	1	Float Ball	JD1416-01	COML	
6	1	Rod,BR Flat,1/4x 5-5/8	JD1416-02	COML	
7	1	Float Valve	JD2988	ROCKFORD- ECLIPSE	922002-1
10	3	Nipple,PI,BR,SD,1/2 CL	JD3094	COML	
11	1	Bushing,HX,125,BR,3/4x1/2	JD3096	COML	
13	1	Valve,Ball,1/4 Turn, 1/2NPT	JD3566-01	DYNAQUIP	VWA1-A8-1/2"
14	1	Strainer	JD3843	JENNY	
16	1	Plug,Pipe, 3/4 NPT	JD7000	COML	
17	1	Tee, Service, 3/4NPT,BZ	JD7000-01	COML	
18	1	Nut, Hose	JP 635-A	JENNY	
19	1	Ferrule, 1/2	JP2126	JENNY	Note 1
20	1	Bushing, Strainer,BR	JP6594	JENNY	
21	1	Water Tank Fittings	JP6736-A	JENNY	
22	1	Float Tank Assy.	JP7205	JENNY	
23	1	"Y" Strainer	JD6161	UNITED BRASS	275115
23A	1	50 Mesh Element	JD6161-01	UNITED BRASS	200-D-A
23B	1	Disc, Copper Clad	JD6161-02	UNITED BRASS	200-C-G
23C	1	Cap, Brass, 3/4	JD6161-03	UNITED BRASS	200-C
23D	1	Plug, 3/8	JD6161-04	UNITED BRASS	200-P

Note 1 - NSN 4730-00-625-2607

☐ THESE PARTS ARE FOR REF. ONLY AND ARE NOT INCLUDED WITH THIS B/M.

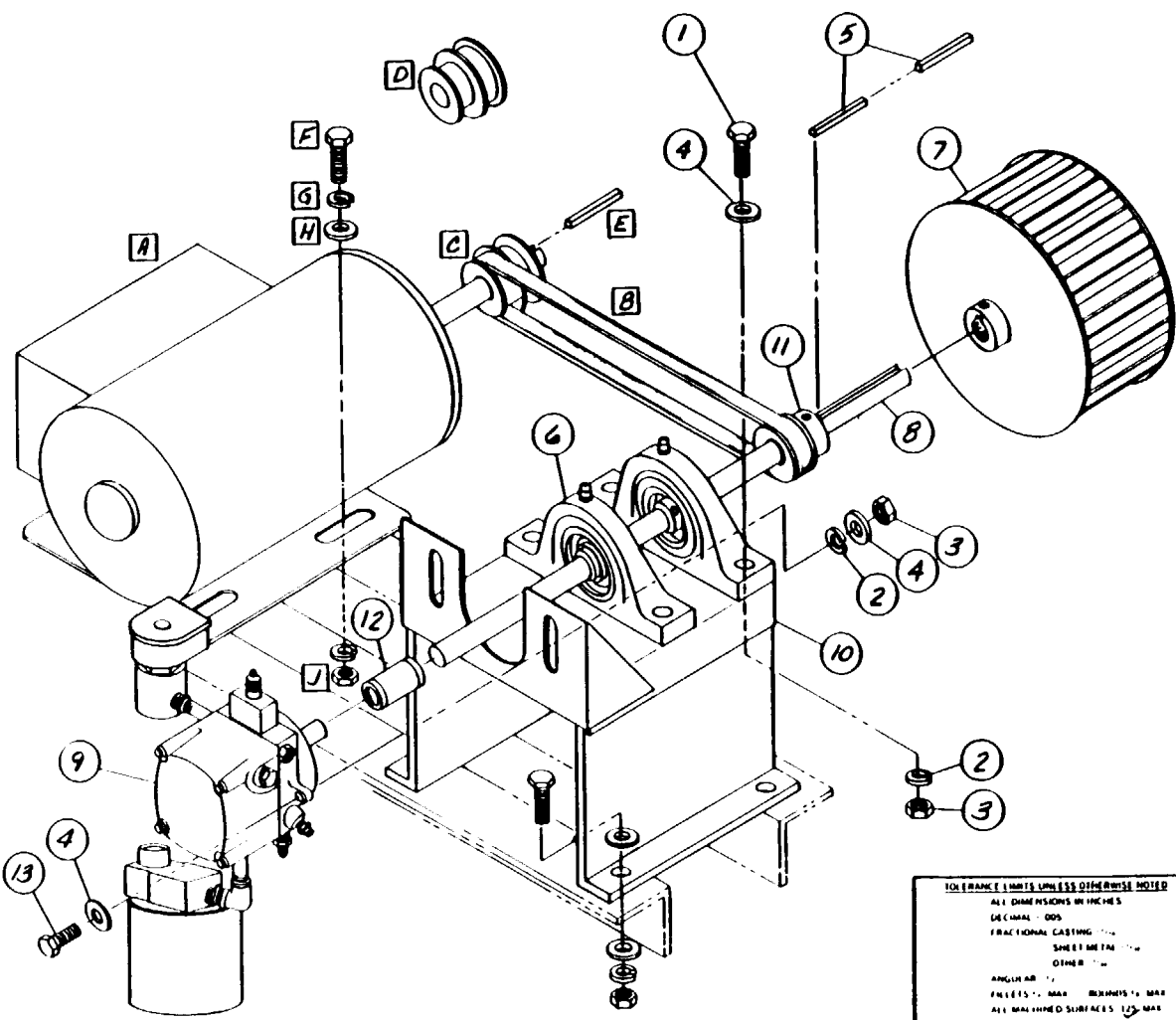

ITEM	PART NO.	QTY.	DESCRIPTION
1	JD546	4	CAPSCREW, 5/16 x 1/2
2	JD612	6	LOCKWASHER, 5/16
3	JE755	6	NUT, 5/16
4	JD894	8	FLAT WASHER, 5/16
5	JD950	2	KEY
6	JP1197-01	2	PILLOW BLOCK, 5/8
7	JD2989	1	BLOWER WHEEL
8	JP6915	1	JACKSHAFT
9	JP7209-A	1	FUEL PUMP & FTGS.
10	JP7218	1	BRACKET
11	JD7004	1	PULLEY
12	JD6101	1	COUPLER ASSY.
13	JD557	2	CAPSCREW, 5/16 x 1

A	JD3984-E	1	MOTOR, 1/2 HP.
B	JD7017	1	BELT, 3L
C	JD3730	1	PULLEY, 60 HZ.
D	JD3745	1	PULLEY, 50 HZ.
E	JD950	1	KEY
F	JD557	8	CAPSCREW
G	JD612	12	LOCKWASHER
H	JD894	12	FLAT WASHER
J	JE755	8	NUT

52

CHG NO	REV	DESCRIPTION	DATE
			(5237)
TITLE			
FUEL SYSTEM AND BLOWER ASSY.			
R.I. 2400			
DATE	DR BY	PRINTED	
11-16-84	MJK		
SCALE	CHK	DWG & PART NO	
	CHK	JP 7209	

TOLERANCE LIMITS UNLESS OTHERWISE NOTED
 ALL DIMENSIONS IN INCHES
 DECIMAL .005
 FRACTIONAL CASTING 1/16
 SHEET METAL 1/32
 OTHER .015
 ANGULAR .1
 FILLETS .03125 MAX RADIUS .03125 MAX
 ALL MATHED SURFACES 1/32 MAX

FUEL SYSTEM AND BLOWER ASSY. JP7209

ITEM	QTY	DESCRIPTION	JENNY P/N	VENDOR	VENDOR P/N
1-13	1	Fuel System & Blower Assy	JP7209	JENNY	
1	4	Screw,CP,HH,S,2,BZ,5/16x1-1/2	JD 546	COML	
2	6	Washer,SK,EXT,S,BZ, 5/16	JD 612	COML	
3	6	Nut, H,DC,F,S,BZ, 5/16C	JE 755	COML	
4	8	Washer,FT,USS,S,BZ, 5/16	JD 894	COML	
5	2	Key,SA,S,3/16x3/16x1-1/4	JD 950	COML	
6	2	Bearing,PB,5/8 x 1/4-28	JP1197-01	MORSE	NP10
7	1	Wheels, Blower, 3/8 ID	JD2989	REVCOR	B762-400HS
8	1	Jackshaft	JP6915	JENNY	
9	1	Fuel Pump & Ftgs Assy	JP7209-A	JENNY	
10	1	Pillow block Mtg. Brkt Weld Asy	JP7218	JENNY	
11	1	Pulley, Jackshaft	JD7004	JENNY	
12	1	Coupling Assembly,5/16x5/8x1-3/4	JD6101	PIONEER	No. Part No. Desc. Only
13	2	Screw,CP,HH,S,2,BZ,5/16 x 1	JD 557	COML	
A	1	Motor, 1-1/2 HP	JD3984-E	JENNY	
B	1	Belt, 3L #3L250	JD7017	COML	3L - 25"
C	1	Pulley, 60 Hz, 2 Gr,3L 4L	JD3730	JENNY	
D	1	Pulley, 50 Hz 2 Gr, 3L 4L	JD3745	JENNY	
E	1	Key,SA,S,3/16x3/16x1-1/4	JD 950	COML	
F	8	Screw,CP,HH,S,2,BZ,5/16x1	JD 557	COML	
G	12	Washer, SK,EXT,S,BZ,5/16	JD 612	COML	
H	12	Washer,FT,USS,S,BZ, 5/16	JD 894	COML	
J	8	Nut, H,DC,F,S,BZ, 5/16C	JE 755	COML	

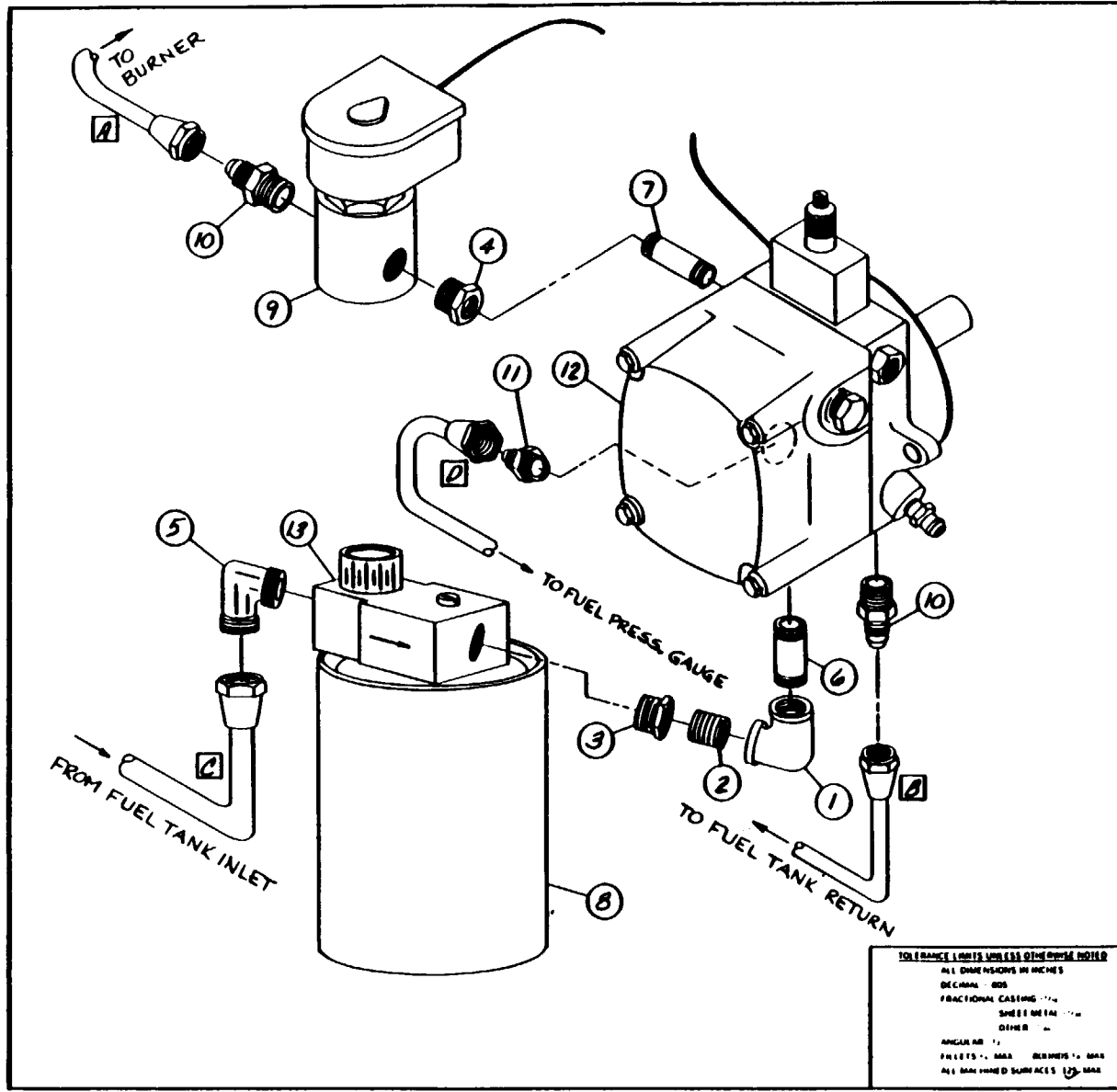

ITEM	PART NO.	QTY.	DESCRIPTION
1	JD 693	1	ELBOW, 1/4
2	JD 714	1	NIPPLE, 1/4, CLOSE
3	JD 673	1	BUSHING, 3/8 x 1/4
4	JD 672	1	BUSHING, 1/4 x 1/8
5	JD 684	1	ELBOW, 3/8-45 x 3/8 NPT
6	JD 910	1	NIPPLE, 1/4 x 1 1/2
7	JD 2775	1	NIPPLE, 1/8 x 1 1/2
8	JD 2117-01	1	ELEMENT, FILTER 24 104
9	JD 1649-F	1	VALVE, FUEL SOLENOID
10	JD 659	2	CONNECTOR, 1/4-45 x 1/4 NPT
11	JD 656	1	CONNECTOR, 1/4-45 x 1/8 NPT
12	JP 7116	1	FUEL PUMP (2) STAGE
13	JD 2181	1	FUEL FILTER

- A JD 1722-55 1 COPPER TUBING ASSY.
- B JD 1722-80 1 COPPER TUBING ASSY.
- C JD 1722-62 1 COPPER TUBING ASSY.
- D JD 1722-68 1 COPPER TUBING ASSY.

THESE PARTS ARE FOR REF. ONLY AND ARE NOT INCLUDED WITH THIS B/M.

CHG NO.	REV.	DESCRIPTION	DATE
			3157
TITLE			
FUEL PUMP & FITTINGS ASSY.			
R.I. 2400			
DATE	DR. BY	PRINTED	
11-7-84	HJK		
SCALE	CHK.	DWG & PART NO.	
		JP 7209-A	

TOLERANCE UNITS UNLESS OTHERWISE NOTED
 ALL DIMENSIONS IN INCHES
 DECIMAL .005
 FRACTIONAL CASTING 1/16
 SHEET METAL .015
 OTHER .010
 ANGULAR .010
 FILLETS .010 MAX RADIUS .010 MAX
 ALL MACHINED SURFACES .010 MAX

FUEL PUMP & FITTINGS ASSEMBLY JP7209-A

ITEM	QTY	DESCRIPTION	JENNY P/N	VENDOR	VENDOR P/N
1-13	1	Fuel Pump & Fittings Assy	JP7209-A	JENNY	
1	1	Elbow,90,150,MI,BK,1/4	JD 693	COML	
2	1	Nipple,PI,S,BK,XH,CL,1/4	JD 714	COML	
3	1	Bushing,HX,2000,S,3/8x1/4	JD 673	COML	
4	1	Bushing,HX,2000,S,GL,1/4x1/8	JD 672	COML	
5	1	Elbow,90,BR,3/8-45x3/8NPTM	JD 684	COML	
6	1	Nipple,1/4 x 1-1/2	JD 910	COML	
7	1	Nipple,PI,S,BLK,SD,1/8x1-1/2	JD2775	COML	
8	1	Element Filter 24104	JD2117-01	WIX	24104
9	1	Valve, Fuel Solenoid 280 PSI	JD1649-F	AUTOMATIC SWITCH CO	8262021V
10	2	Connector,ST,BR,1/4-45x1/4NPTM	JD 659	COML	
11	1	Connector,ST,BR,1/4-45x1/8NPTM	JD 656	COML	
12	1	Fuel Pump (2) Stage	JP7116	JENNY	
13	1	Filter, Fuel Oil,3/8	JD2181	WIX	#24102
A	1	Copper Tubing Assy, 1/4 x 55 "	JD1722-55	COML	
B	1	Copper Tubing Assy, 1/4 x 80 "	JD1722-80	COML	
C	1	Copper Tubing Assy, 3/8 x 62 "	JD1732-62	COML	
D	1	Copper Tubing Assy, 1/4 x 68 "	JD1722-68	COML	

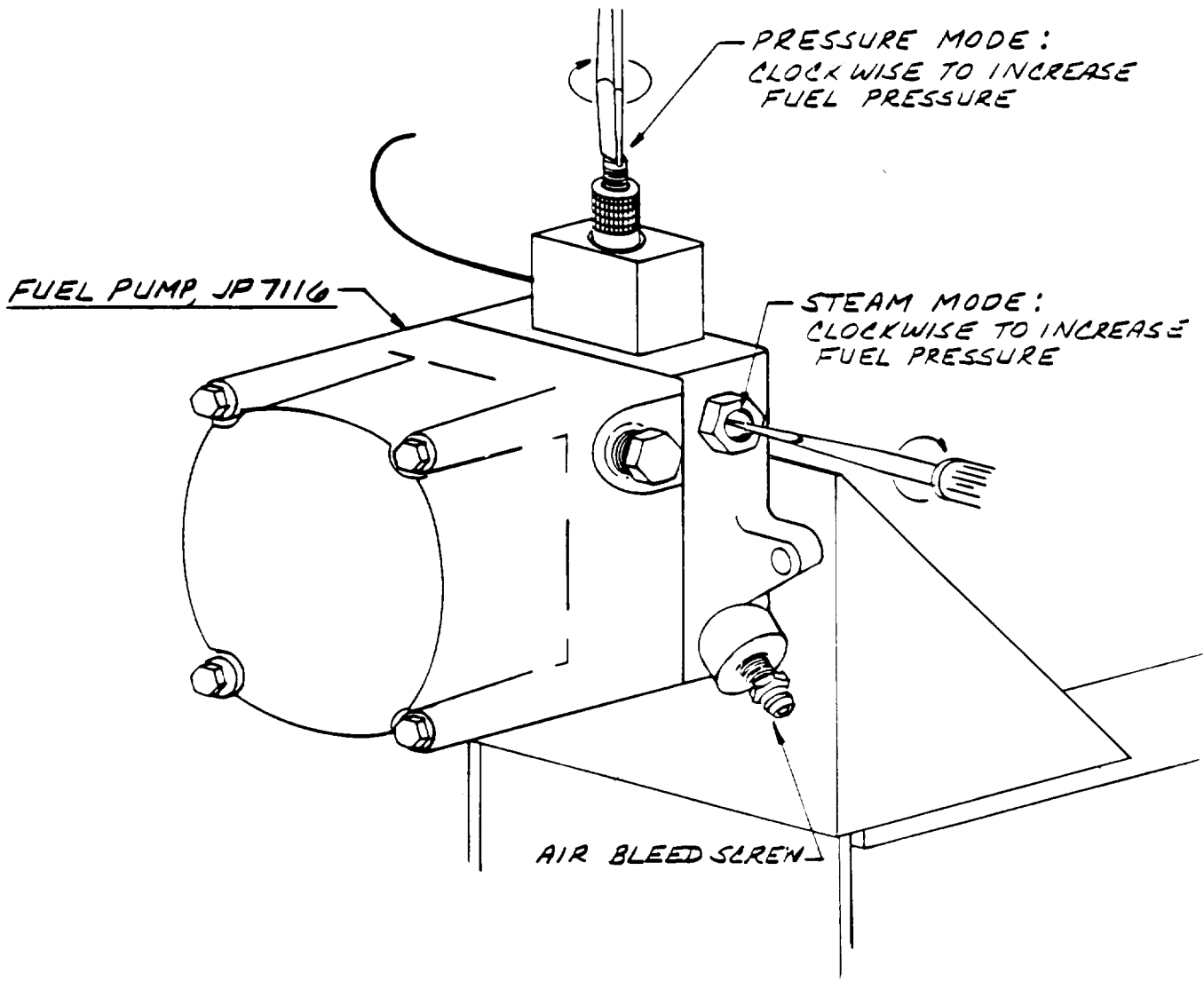

CHANGE NUMBER	REV.	DESCRIPTION	DATE
			5-57
TITLE FUEL PUMP ADJUSTMENT R.I. 2400			
11-13-84	DR. BY MJK	PRINTED	
SCALE		SUPERSEDES	
		DWG. & PART NO.	
		JP 7209-D	

TOLERANCES UNLESS OTHERWISE NOTED

DECIMAL = .005
 FRACTIONAL CASTINGS = 1/16 OTHER = 1/64
 SHEET METAL = 1/32
 ANGULAR = 1/4°
 FILLETS: 1/4" MAX. ROUNDS: 1/8" MAX.
 ALL MACHINED SURFACES 125/ MAX.
 ALL DIMENSIONS IN INCHES

BRUNING 40 21 44339

THIS PAGE LEFT INTENTIONALLY BLANK

ITEM	PART NO.	QTY.	DESCRIPTION	ITEM	PART NO.	QTY.	DESCRIPTION
A	JP4739	1	FLAT NOZZLE, 2"	1	JD1677	1	VALVE, 3/8, KINGSTON
B	JP4740	1	FLAT NOZZLE, 4"	2	JD1488	1	SWIVEL ASSY
C	JD3691	1	PRESSURE TIP, 25°	3	JE280-A	1	HANDLE ASSY.
D	JD673	1	BUSHING, 3/8 x 1/4	4	JD1140	1	NIPPLE, 3/8 x 22" LG.
E	JP312506	1	NOZZLE ORIFICE	5	JD907	2	COUPLING, 3/8
F	JP330801	1	STEAM NOZZLE	6	JD704	1	ELBOW, 45°, 3/8
				7	JD919	1	NIPPLE, 3/8 x 6" LG.
				8	JP72101	1	VALVE HANDLE
				9	JD148701	1	HANDLE GRIP
				10	JP7250	1	PIPE HANDLE
				11	JE558-05	1	HAND GRIP
				12	JD736	1	BUSHING, 3/8 x 1/2
				13	JD915	1	ELBOW, 1/2, 45°

☐ THESE PARTS ARE FOR REF. ONLY AND ARE NOT INCLUDED WITH THIS D/W.

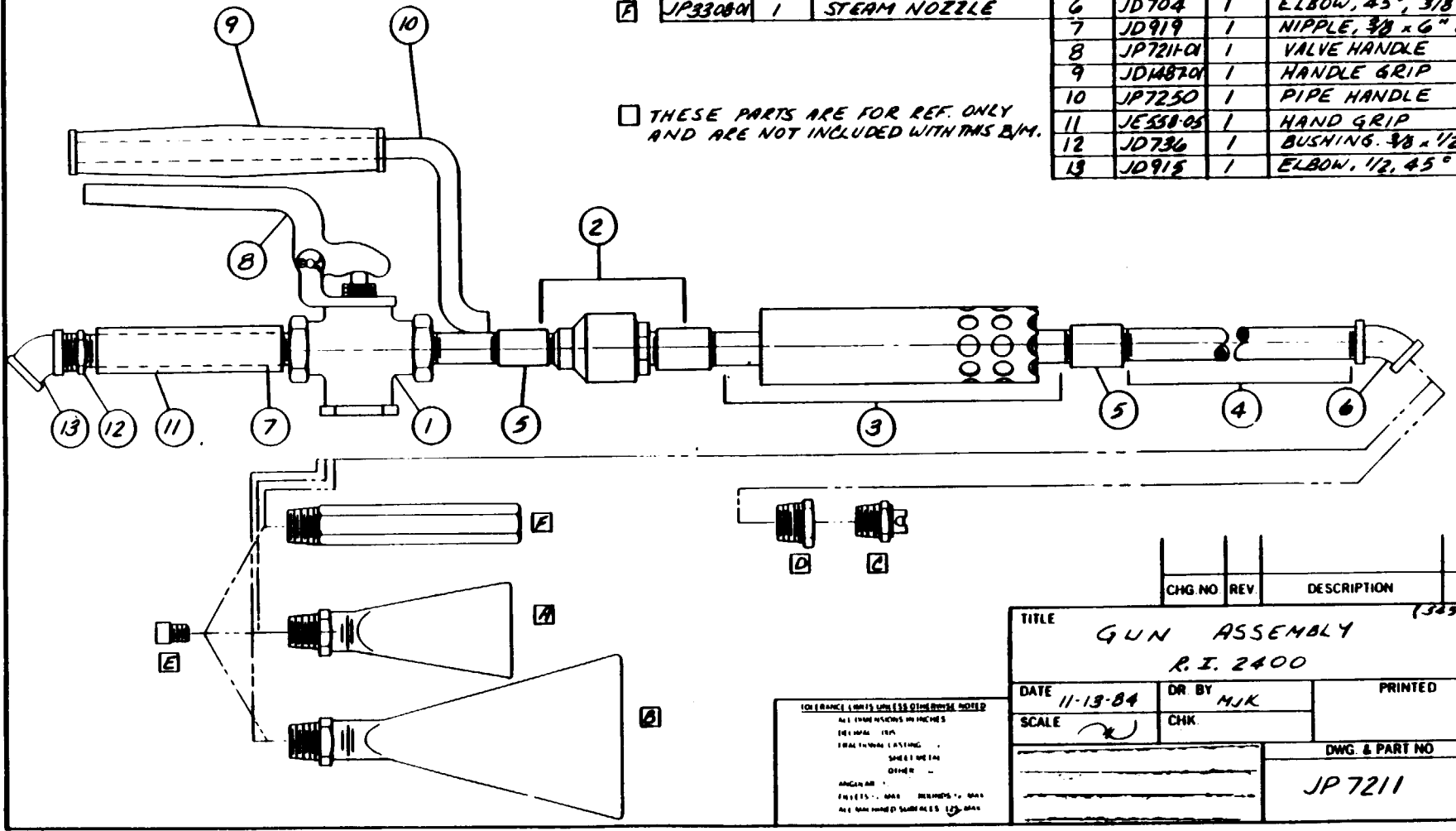

58

CHG NO	REV	DESCRIPTION	DATE
			(3457)
TITLE GUN ASSEMBLY R.I. 2400			
DATE	11-13-84	DR BY	MJK
SCALE	2	CHK	
		PRINTED	
			DWG. & PART NO
			JP 7211

CONFORMANCE UNLESS OTHERWISE NOTED
 ALL DIMENSIONS IN INCHES
 DECIMALS - .001
 FRACTIONS - 1/16
 ANGLES -
 FINISHES -
 ALL DIMENSIONS UNLESS OTHERWISE NOTED

GUN ASSEMBLY - JP7211

ITEM	QTY	DESCRIPTION	JENNY P/N	VENDOR	VENDOR P/N
1-13	1	Gun Assembly	JP7211	JENNY	
1	1	Valve, 3/8"	JD1677	COML	
2	1	Swivel Assembly	JD1488	JENNY	Note 1
3	1	Handle Assembly	JE 280-A	JENNY	
4	1	Nipple, 3/8 x 22	JD1140	COML	
5	2	Coupling	JD 907	JENNY	
6	1	Elbow, 45°, 3/8	JD 704	COML	
7	1	Nipple, 3/8 x 6" Lg	JD 919	COML	
8	1	Valve Handle	JP7211-01	JENNY	
9	1	Handle Grip	JD1487-01	JENNY	Note 2
10	1	Pipe Handle	JP7250	JENNY	
11	1	Hand Grip	JE 558-05	JENNY	
12	1	Bushing, 3/8 x 1/2	JD 736	COML	
13	1	Elbow, 1/2"	JD 915	COML	
A	1	Flat Nozzle, 2"	JP4739	JENNY	Note 3
B	1	Flat Nozzle, 4"	JP4740	JENNY	Note 4
C	1	Pressure Tip, 25°	JD3691	COML	
D	1	Bushing, 3/8 x 1/4	JD 673	COML	
E	1	Nozzle Orifice	JP3175-06	JENNY	
F	1	Steam Nozzle	JP3308-01	JENNY	

Note 1 - NSN 4730-00-737-9528

Note 2 - NSN 5340-00-723-5426

Note 3 - NSN 4738-00-456-1141

Note 4 - NSN 4730-00-456-1140

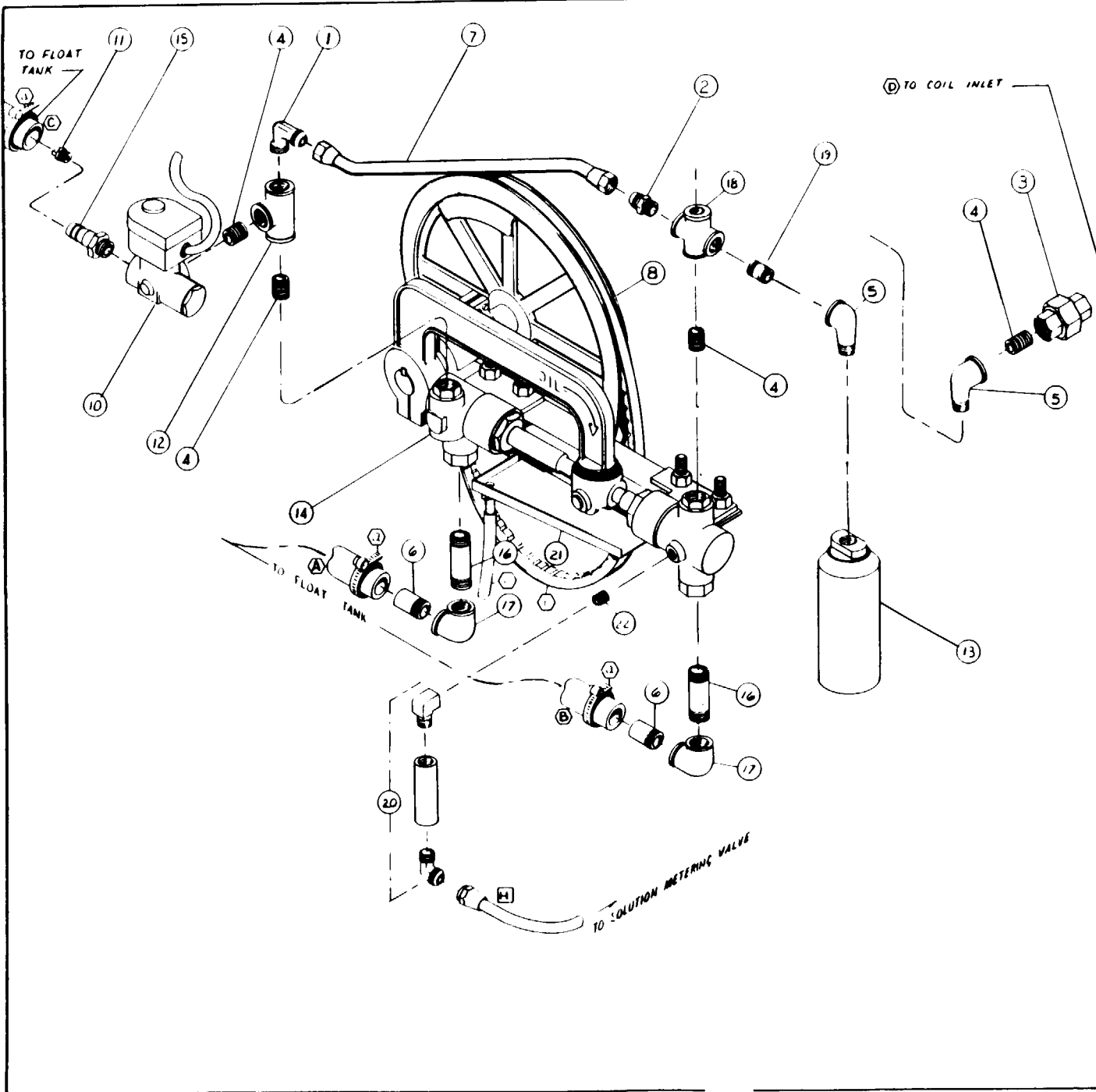

ITEM	QTY	PART NO	DESCRIPTION
1	1	JD684	ELBOW 1/4" x 1/8" 45 BR
2	1	JD687	CONNECTOR 1/8" x 1/8" 45 BR
3	1	JD701	UNION 1/8"
4	6	JD712	NIPPLE 1/8" CL
5	2	JD814	ELL ST 1/8"
6	2	JD975-01	NIPPLE 1/8" T O E, BRASS
7	1	JD1732-11	TUBING ASSY 1/8"
8	1	JD2145 A	PULLER
9	2	JD3058	ELL ST 1/8" BR
10	1	JD3063 A	VALVE SOLENOID
11	1	JD3810	TIP RW 15080
12	1	JD1197	TEE 1/8"
13	1	JD6093-E	ACCUMULATOR, 150 PSI
14	1	JP3245	PUMP ASSY
15	1	JP689B	NIPPLE HOSE + DRIFICE
16	2	JD737-05	NIPPLE, 1/8" x 2" BR
17	2	JD691-01	ELBOW 1/8" BRASS, 90°
18	1	JD952	CROSS 1/8"
19	1	JD621C	NIPPLE, 1/8" x 1/4"
20	1	JP7247	SL. T. ON CHECK VALVE ASSY
21	1	JP4334	DRIP PAN
22	1	JD714	NIPPLE 1/8" CL

□ THESE PARTS ARE FOR REF. ONLY AND ARE NOT INCLUDED WITH THIS Q/M

- 1 JD1722-3E COPPER TUBING ASSY
- ⊕ 1 JL146 DB HOSE 1/8" ID - 8 LC
- ⊕ 1 JL146 22 HOSE 1/8" ID - 22 LC
- ⊕ 1 JL146 38 HOSE 1/8" ID - 38 LC
- ⊕ 1 JP293J A ACCUMULATOR HOSE ASSY
- ⊕ 1 JD1229 HOSE CLAMP
- ⊕ 1 JE 877 BELT V CUG
- ⊕ 12" JD2183-14 TUBE 1/8" ID - 16" LC

69

REV	WORK ORDER	DATE
5		
4		
3		
2		
1		

TITLE
PUMP & FITTINGS ASSY
 R1 2400 DES

DATE 7-8-88
 SCALE ~

DESIGNED BY CL
 CHECKER JG/ALC

WORK ORDER NO
JP7212

PUMP & FITTINGS ASSEMBLY JP7212

ITEM	QTY	DESCRIPTION	JENNY P/N	VENDOR	VENDOR P/N
1-22	1	Pump & Fittings Assembly	JP7212	JENNY	
1	1	Elbow,90,BR,3/8-45x3/8NPTM	JD 684	COML	
2	1	Connector,ST,BR,3/8-45x3/8NPTM	JD 687	COML	
3	1	Pipe Union,3/8,W/O Ring Seal	JD 701	COML	
4	6	Nipple,PI,S,BK,XH,CI,3/8	JD 712	COML	
5	2	Elbow,ST,90,150,MI,Bk,3/8	JD 814	COML	
6	2	Nipple,Pipe,BR,3/8x1-1/2 Std	JD 975-01	COML	
7	1	Copper Tubing Assy, 3/8 x 11	JD1732-11	COML	
8	1	Pulley Assembly	JD2145-A	JENNY	
9	2	Elbow,90,DP,125,BR,3/8	JD3058	COML	
10	1	Valve,So,BR,3/8	JD3063-A	ASCO	8223A23
11	1	Tip, Pressure Wash,15080	JD3810	JENNY	
12	1	Tee,150,MI,BK,3/8	JD 697	COML	
13	1	Accumulator, 150# PSI	JD6093-E	JENNY	
14	1	Pump Assembly Duplex	JP3245	JENNY	Note 1
15	1	Hose & Orifice Nipple	JP6898	JENNY	
16	2	Nipple,Brass,3/8x2	JD 732-05	COML	
17	2	Elbow,3/8" Brass, 90°	JD 691-01	COML	
18	1	Cross, 150 MI,BK,3/8	JD 952	COML	
19	1	Nipple,Pipe,Stl,Blk,3/8x1-1-1/4	JD6210	COML	
20	1	Solution Check Valve Assembly	JP7247	JENNY	
21	1	Drip Pan Assembly	JP4334	JENNY	Note 2
22	1	Nipple,PI,S,BK,XH,CL,1/4	JD 714	COML	
H	1	Copper Tubing Assembly	JD1722-44	COML	
A	1	Hose, 5/8ID x 8" LG	JL 146-08	COML	
B	1	Hose, 5/8ID x 22" LG	JL 146-22	COML	
C	1	Hose, 3/4ID x 38" LG	JE 558-38	COML	
D	1	Alleviator Hose Assy.	JP2930-A	JENNY	
a	6	Hose Clamp	JD1229	COML	
b	1	Belt, V Cog,3/8" x 46.3 O.C.	JE 877	COML	Note 3
c	1.2'	Tube, 5/16 ID, x 14" LG	JD2183-14	COML	

Note 1 - NSN 4940-00-136-2257

Note 2 - NSN 4940-00-400-2517

Note 3 - NSN 3030-00-080-8817

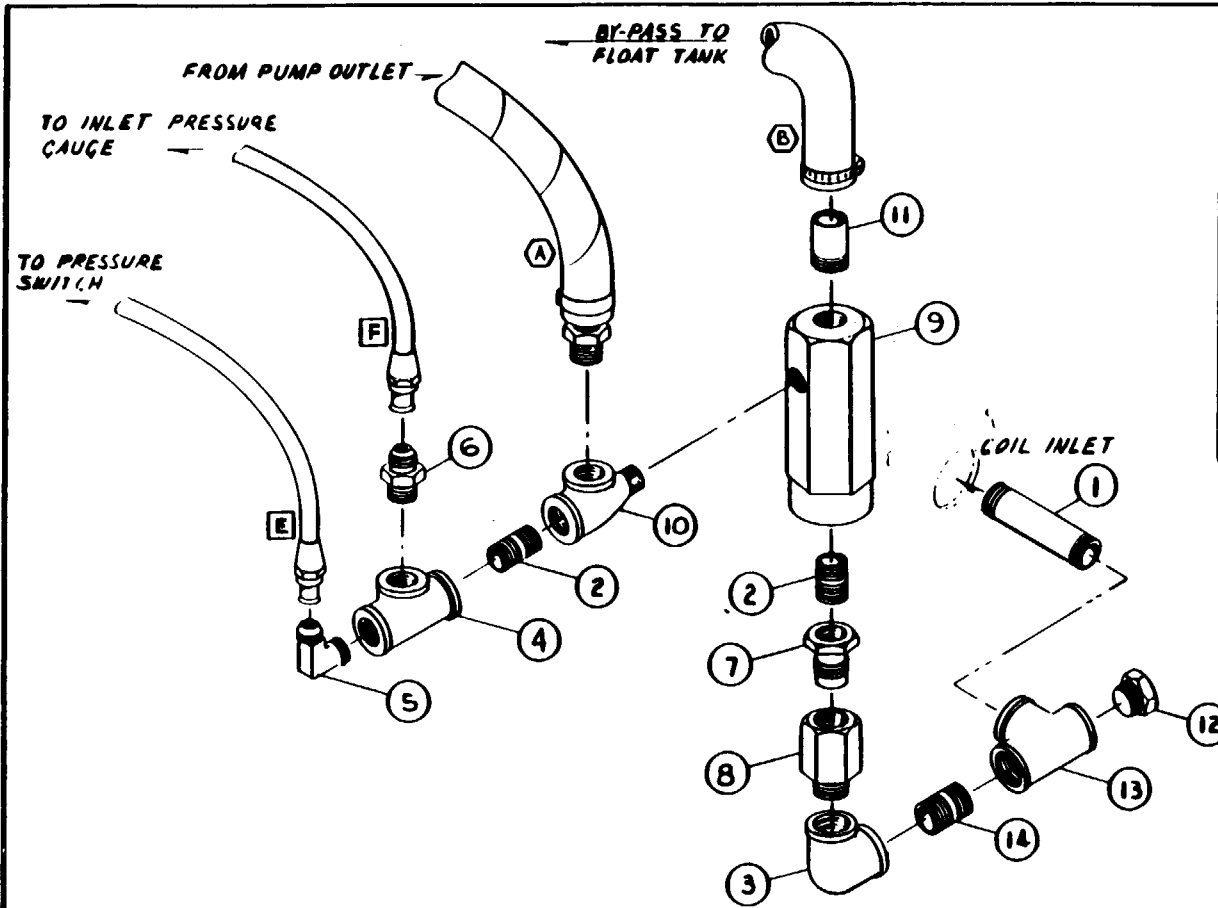

ITEM	QTY	PART NO	DESCRIPTION
1	1	JD1182	NIPPLE, 1/2 x 3
2	2	JD 712	NIPPLE, 1/8 CL
3	1	JD1030	ELBOW, RD, 1/2 x 3/8
4	1	JD2326	TEE, 1/8
5	1	JD 678	ELBOW, 1/8, 45 x 1/8 NPTM
6	1	JD1277	CONNECTOR 1/8, 45 x 1/8 NPTM
7	1	JP3208-A	INLET CHECK VALVE ASSY
8	1	JP6531-01	ADAPTOR, 3/8 NPT
9	1	JP7117	UNLOADER
10	1	JD 860	TEE, 1/8, ST
11	1	JE 554-02	NIPPLE, 1/2 TOE
12	1	JD2648	PLUG, 1/2
13	1	JD 696	TEE, 1/2
14	1	JP 981	NIPPLE, 1/2 CL.

- E 1 JD1722-14 COPPER TUBING, A...
- F 1 JD1722-28 COPPER TUBING ASS...
- A 1 JP2930-A ALLEVIATOR HOSE ASSY
- B 1 JE 558 60 BY-PASS HOSE

E A } THESE PARTS ARE FOR REF. ONLY AND ARE NOT INCLUDED WITH THIS Q/M

5457	REV.	DESCRIPTION	DATE

TITLE
COIL INLET FITTINGS ASSY
 R 2 2400

DATE	DR. BY	PRINTED
11 MAR 64	CL	
SCALE	CHK.	
		DWG. & PART NO.
		JP7219

TOLERANCE LIMITS UNLESS OTHERWISE NOTED
 ALL DIMENSIONS IN INCHES
 DECIMALS .005
 FRACTIONS CASTINGS 1/16
 SHEET METAL 1/32
 OTHER .015
 ANGLES AS SHOWN
 HOLE SIZES TO MAX UNLESS OTHERWISE NOTED
 ALL UNFINISHED SURFACES 1/16

COIL INLET FITTINGS ASSEMBLY JP7219

ITEM	QTY	DESCRIPTION	JENNY P/N	VENDOR	VENDOR P/N
1-14	1	Coil Inlet Fittings Assy.	JP7219	JENNY	
1	1	Nipple,PI,S,BLK,SD,1/2x3	JD1182	COML	
2	2	Nipple,PI,S,BK,XH,CL,3/8	JD 712	COML	
3	1	Elbow,RD,90,150,MI,BK,1/2x3/8	JD1030	COML	
4	1	Tee,300,MI,BK,3/8	JD2326	COML	
5	1	Elbow,90,BR,1/4-45x3/8NPTM	JD 678	COML	
6	1	Connector,ST,BR,1/4-45x3/8NPTM	JD1277	COML	
7	1	Inlet Check Valve Assy.	JP3208-A	JENNY	Note 1
8	1	Adaptor, 3/8 NPT	JP6531-01	COML	
9	1	Unloader	JP7117	JENNY	
10	1	Tee,ST,150,MI,BK,3/8	JD 860	COML	
11	1	Nipple, Hose,BR,SD,1/2x1-1/2	JE 554-02	COML	
12	1	Plug,HS,S,1/2	JD2648	COML	
13	1	Tee,150,MI,BK,1/2	JD 696	COML	
14	1	Nipple,PI,S,BLK,SD,1/2CL	JP 981	COML	
E	1	Copper Tubing Assembly	JD1722-14	COML	
F	1	Copper Tubing Assembly	JD1722-28	COML	
A	1	Alleviator Hose Assembly		JENNY	
B	1	By Pass hose		COML	

E	1	Copper Tubing Assembly 1/4" x 14" long			
F	1	Copper Tubing Assembly 1/4" x 28" long			

Note 1 - NSN 4820-00-724-3732

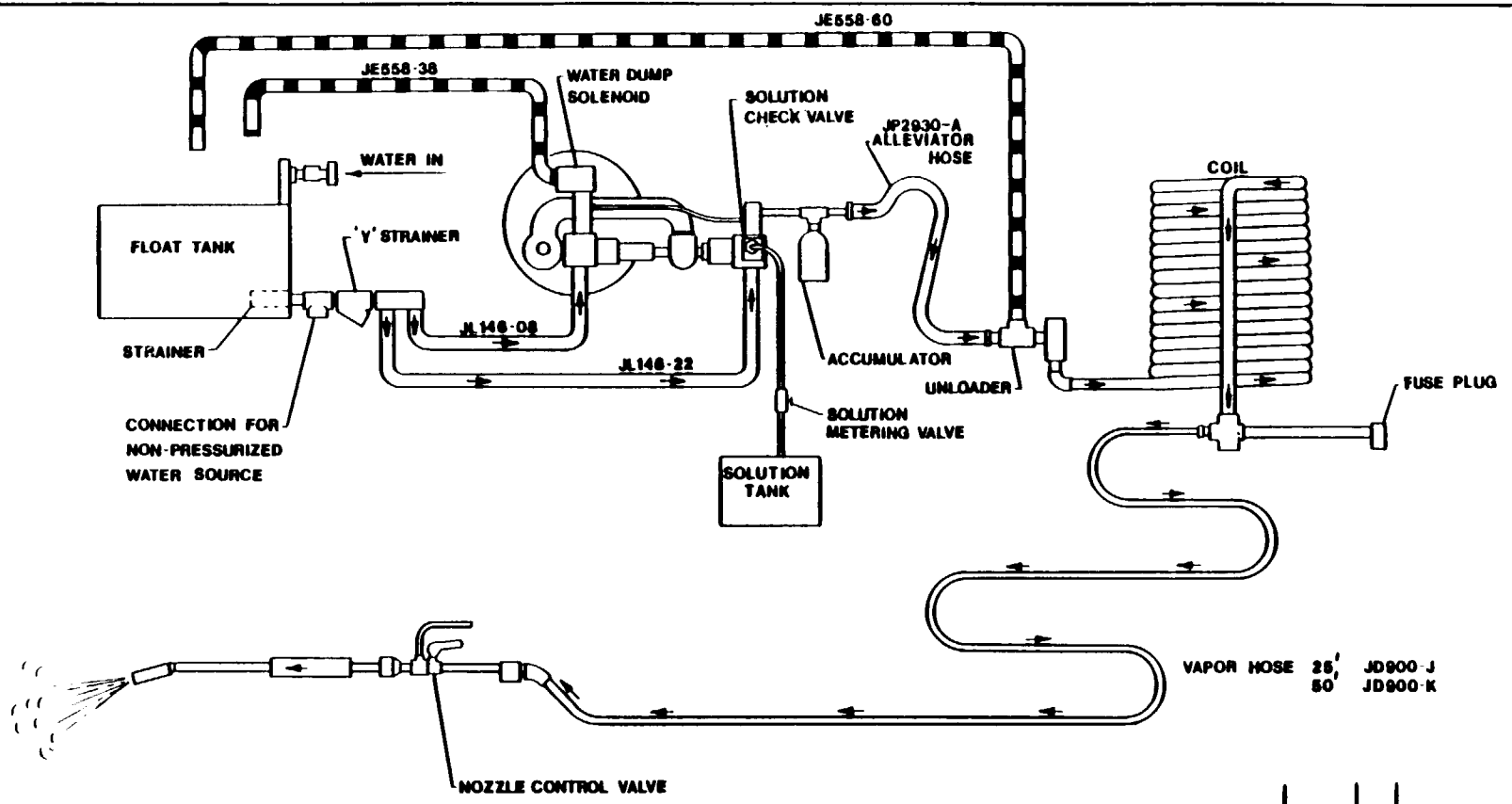

64

TOLERANCE LIMITS UNLESS OTHERWISE NOTED
 ALL DIMENSIONS IN INCHES
 DECIMAL .005
 FRACTIONAL CASTING .010
 SHEET METAL .010
 OTHER .010
 ANGULAR .1°
 FILED .005 BAR ROUNDS TO MAX
 ALL MACHINED SURFACES .125 MAX

CHG NO.	REV.	DESCRIPTION	DATE
TITLE			
WATER SYSTEM FLOW DIAGRAM			
R.I. 2400			
DATE	DR. BY	PRINTED	
7-19-84	GL		
SCALE	CHK.	DWG. & PART NO.	
2		JP7221	

THIS PAGE LEFT INTENTIONALLY BLANK

ITEM	QTY	PART NO	DESCRIPTION
1	1	JD265-03	NOZZLE, OIL, 3 GPH
2	1	JD 1002	SCREW, SET
3	2	JD552	SCREW, CAP, 1/4
4	2	JD611	WASHER, LK 1/4
5	2	JD791	NUT, 1/4
6	1	JD1492	WASHER
7	1	JP2904-F	ANTI-SYPHON FTGS ASSY.
8	1	JD3512	NUT, 1/4 N.P.S.
9	1	JL145-22	ELECTRODE
10	2	JP6015-A	CLAMP, ELECTRODE
11	1	JP6162-B	FLAME SWITCH ASSY.
12	1	JP6389-01	BURNER PLATE
13	1	JP6545-01	NIPPLE, BURNER
14	1	JP 7243	WHIRLER / THROAT ASSY.

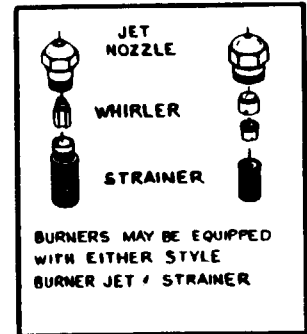
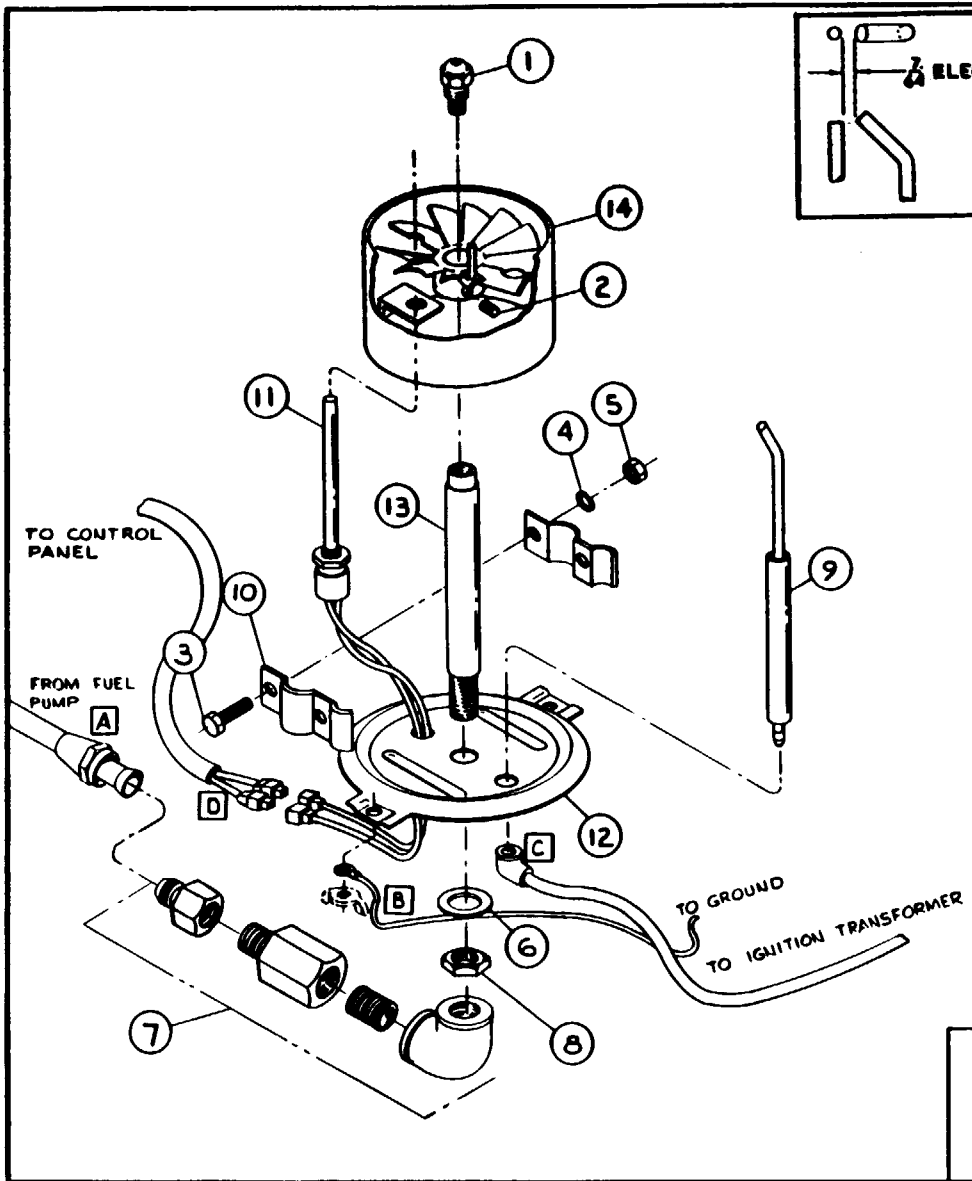
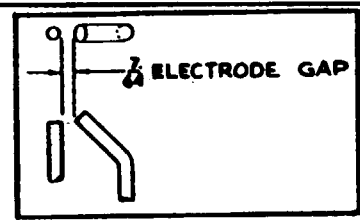

- A** JD1722-55 COPPER TUBING ASSY
- B** JP7240-18 GROUND WIRE ASSY.
- C** JP7239-K IGNITION CABLE
- D** JP7239-F FLAME SWITCH CABLE ASSY.

THESE PARTS ARE FOR REF. ONLY AND ARE NOT INCLUDED WITH THIS B/M.

5457	▲	ADDED CABLES AS REF.	
5457	▲		
CHG. NO.	REV.	DESCRIPTION	DATE

TITLE
BURNER ASSY
R.I. 2400

DATE 7-19-84	DR. BY GL	PRINTED
SCALE X	CHK.	
		DWG. & PART NO. JP7222

TOLERANCE LIMITS UNLESS OTHERWISE NOTED
 ALL DIMENSIONS IN INCHES
 DECIMAL - .005
 FRACTIONAL CASTING - 1/16
 SHEET METAL - 1/32
 OTHER - .010
 ANGULAR - 15
 FILLETS R MAX ROUNDED R MAX
 ALL MACHINED SURFACES 125 MAX

BURNER ASSEMBLY JP7222

ITEM	QTY	DESCRIPTION	JENNY P/N	VENDOR	VENDOR P/N
1-14	1	Burner Assembly	JP7222		
1	1	Nozzle, oil, 3 GPH	JD 265-03	JENNY	
2	1	Screw,ST,HS,S,PL,NY,5/16x3/8	JD1002	COML	
3	2	Screw,CP,HH,S,2,BZ,1/4x1	JD 552	COML	
4	2	Washer, LK,BZ,1/4	JD 611	COML	
5	2	Nut,H,DC,F,S,BZ,1/4	JD 791	COML	
6	1	Washer,FT,SAE,S,BZ,9/16	JD1492	COML	
7	1	Anti-Syphon Fittings Assy	JP2904-F	JENNY	
8	1	Nut,Pal Lock,1/4-18NPS	JD3512	COML	
9	1	Electrode	JL 145-22	JENNY	
10	2	Clamp, Electrode	JP6015-A	JENNY	
11	1	Flame Switch Assembly	JP6162-B	ESSEX	471
12	1	Burner Plate	JP6389	JENNY	
13	1	Nipple, Burner	JP6545-01	JENNY	
14	1	Whirler & Throat Assy	JP7243	JENNY	
A	1	Copper Tubing Assy.	JD1722-55	COML	
B	1	Green Ground Wire 37"	JP7240-18	COML	Note #1
C	1	Ignition Cable 42"	JP7239-K	COML	Note #2
D	1	Flame Switch Cable Assy.	JP7239-F	COML	Note #3

Note#1 - Green Vinyl Wire #16 (26 strands #30) 600 Volt, 90° C.

Note #2 - Type GT0 15 - #14-1, 1500 Volt, Polyetheylene

Note #3 - Type SJO Cable (2 - #18 AWG Wires, Black, White) 300 Volts, 60° C.

88

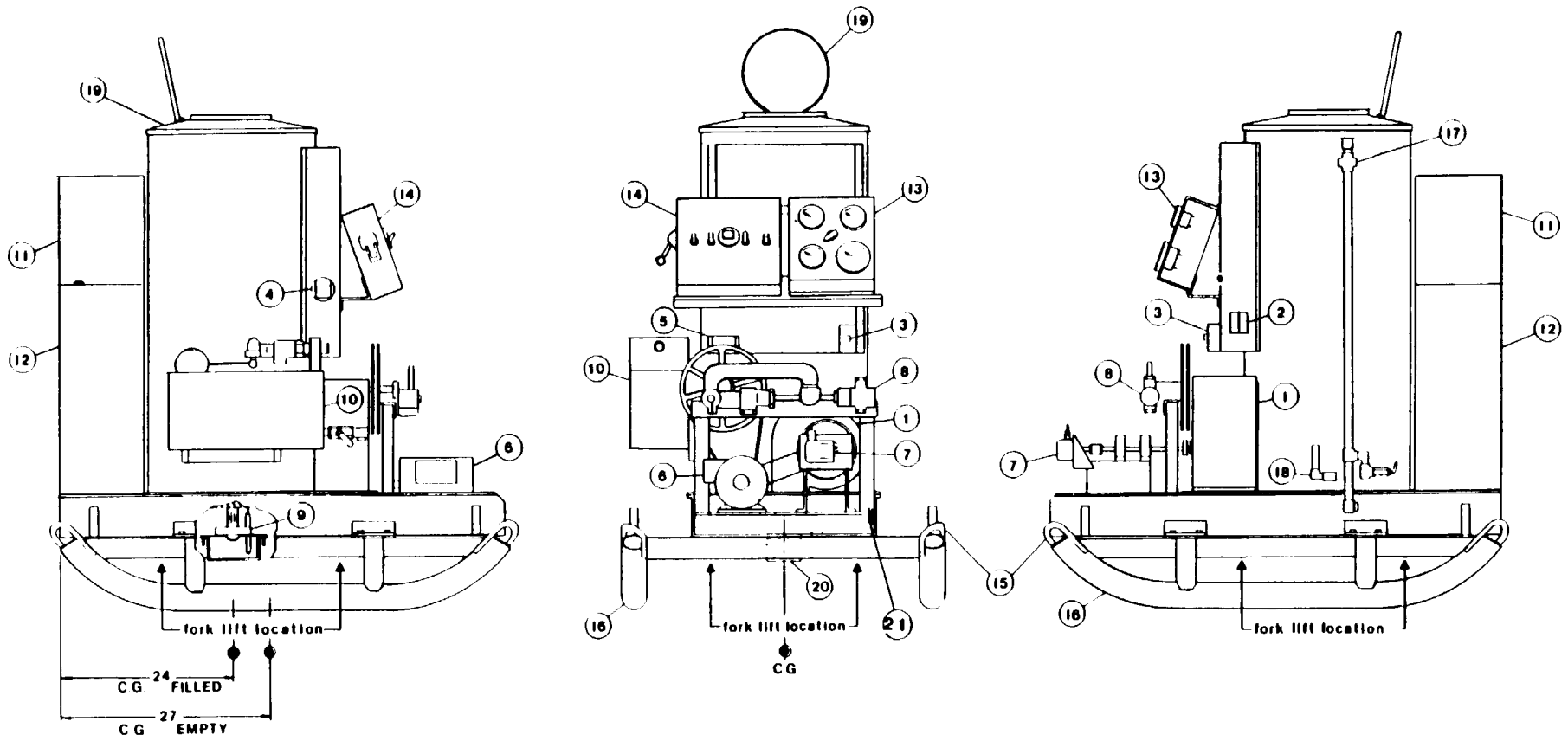

HOSE RACK & HOSES OMITTED FOR CLARITY
 SEE DWGS. SK-45-84
 SK-8-85

REV	WORK ORDER	DATE
TITLE ELEVATIONS RI 2400		
DATE 7-19-84	DR BY MJK	SUPERSEDES
SCALE	CHK	
DWG & PART NO		
		JP 7223

ELEVATIONS - JP7223

ITEM	QTY	DESCRIPTION	JENNY P/N	VENDOR	VENDOR P/N
1	1	Blower Housing	JD2990	DOVER	#750
2	1	Pressure Switch	JD3415	BARKSDALE	96101-BB1-A-TP
3	1	Temperature Control	JD3701-A	WHITE-RODGERS	11B06-31
4	1	Air Differential Switch	JD6168	DWYER	1910-1 SPDT
5	1	Ignition Transformer	JP3913-09	JENNY	
6	1	Motor, 1-1/2 HP	JD3984-E	JENNY	
7	1	Fuel Pump	JP7116	JENNY	
8	1	Water Pump	JP3245	JENNY	
9	1	Burner	JP7222	JENNY	
10	1	Float Tank Ftgs. Assy.	JP7205-A	JENNY	
11	1	Solution Tank	JP7238	JENNY	
12	1	Fuel Tank	JP7110-A	JENNY	
13	1	Gauge Panel Ftgs. Assy.	JP7204-A	JENNY	
14	1	Electrical Control Panel	JP7232	JENNY	
15	4	Lifting Eye			
16	1	Skid Assembly	JP7210	JENNY	
17	1	Vapor Outlet Assembly	JP7231	JENNY	
18	1	Coil Inlet Assembly	JP7219	JENNY	
19	1	Rain Cap - Coil Ring	JP7234	JENNY	
20	1	Burner Guard	JP6187-02	JENNY	
21	1	Pulley, 50 Hz.	JD3745	JENNY	

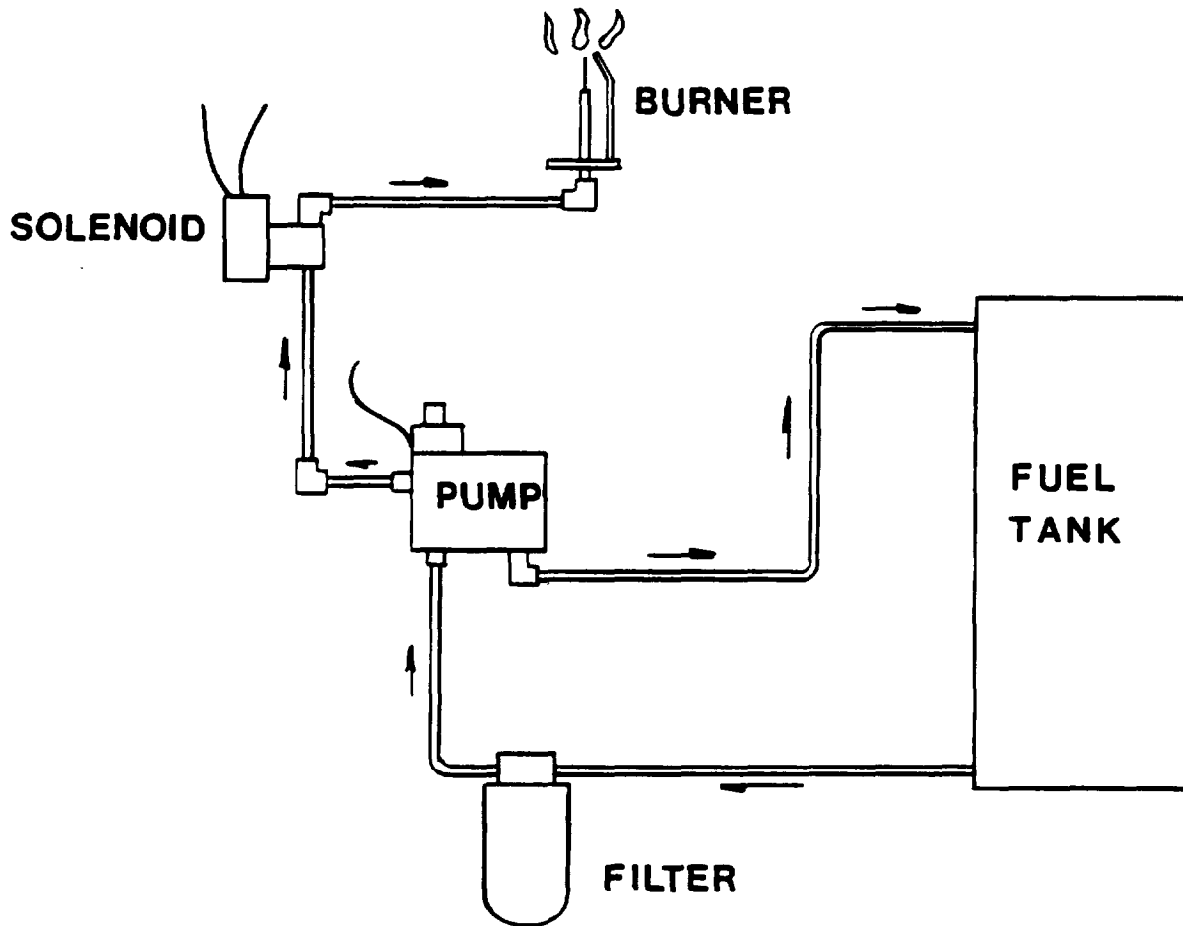

CHANGE NUMBER	REV.	DESCRIPTION	DATE
---------------	------	-------------	------

TITLE
FUEL SYSTEM FLOW DIAGRAM
R.I.2400

7/19/84 DR. BY **MJK** PRINTED

SCALE SUPERSEDES

DWG. & PART NO.

JP 7225

TOLERANCES UNLESS OTHERWISE NOTED

DECIMAL ± .008
 FRACTIONAL CASTINGS ± 1/16 OTHER ± 1/64
 SHEET METAL ± 1/32
 ANGULAR ± 1/4°
 FILLETS: 1/4" MAX. ROUNDS: 1/8" MAX.
 ALL MACHINED SURFACES 125/ MAX.
 ALL DIMENSIONS IN INCHES

BRUNING 40-21 44339

THIS PAGE LEFT INTENTIONALLY BLANK

ITEM	QTY	PART NO.	DESCRIPTION	ITEM	QTY	PART NO.	DESCRIPTION
1				9	1	JD3712	ELBOW ST 1/2 x 3/8
2	1	JD721	NIPPLE, 1/2 x 2	10	3	JD696	TEE, 1/2
3	2	JD760	PLUG, 1/2	11	1	JD678	ELL, 3/8 NPT x 1/8 TUBING
4	1	JD800	ELL, ST 1/2	12	2	JE784	CROSS, 1/2
5	2	JD1019	SLEEVE, 1/2	13	5	JP981	NIPPLE, 1/2 CL.
6	3	JD736	BUSHING, 1/2 x 3/8 ST	14	1	JP2688-01	BODY
7	1	JD3111	NIPPLE, 1/2 x 27 1/2	15	1	JP3921-D	FUSE PLUG
8	1	JD3702	STUFFING BOX	16	1	JD726	NIPPLE, 1/2 x 4
				17	1	JP7241	OUTLET BRACKET
				d	REF.	JP3284-H	DRAIN RELIEF VALVE

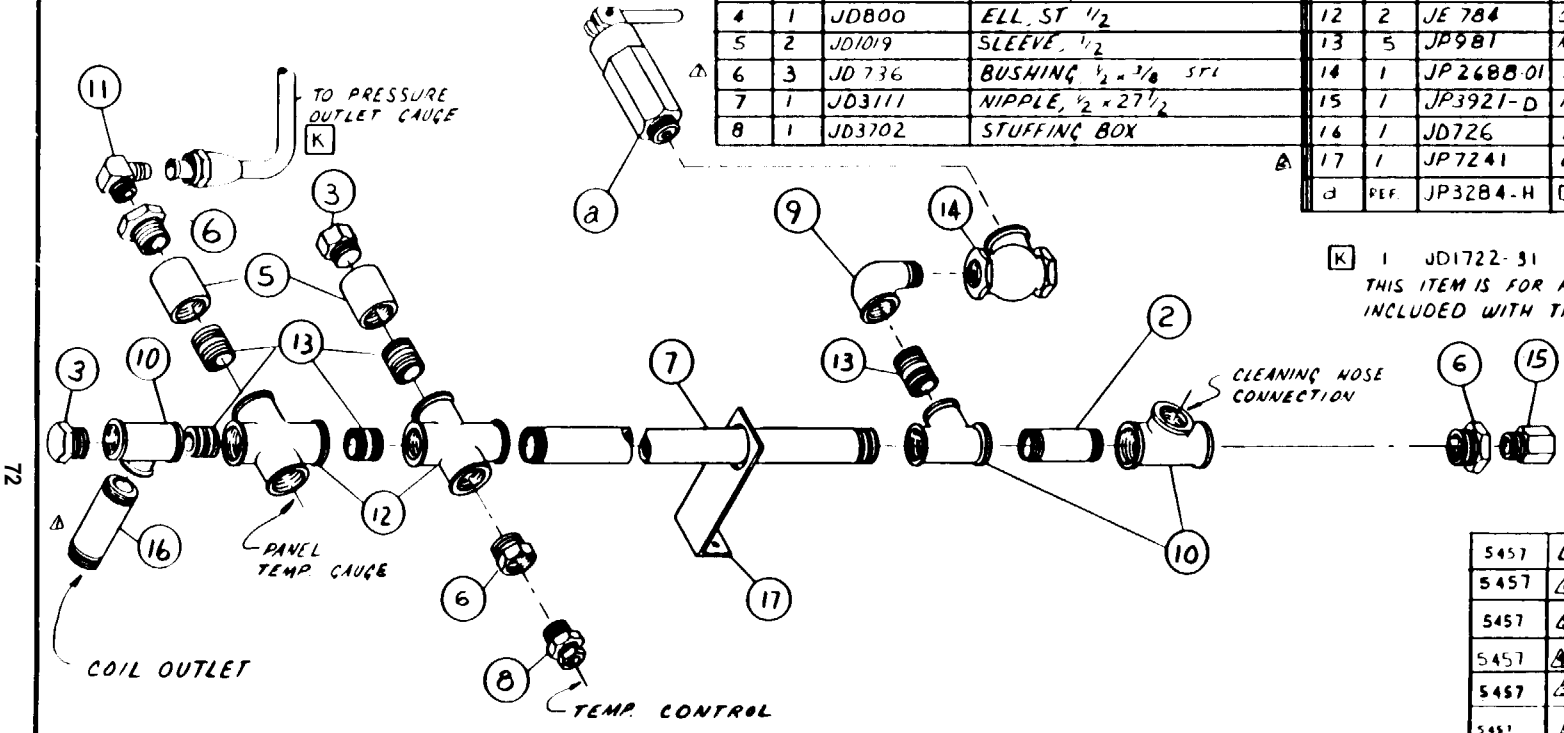

72

5457	Δ	CHANGED 010-16 FROM 04 TO 01	1/15/84
5457	Δ	ADD 3 PLUGS (6) TO THE END	1/15/84
5457	Δ	CHANGED FROM 2 1/2 TO 3 1/2 NIPPLE FROM 1/2 TO 3/4	1/15/84
5457	Δ	ADDED RELIEF VALVE	1/15/84
5457	Δ	REV. 1/15/84	1/15/84
5457	Δ	ADDED TEMP GAUGE	1/15/84
5457	Δ	ADDED HOSE CONNECTION	1/15/84
CHG NO	REV	DESCRIPTION	DATE

TITLE		
VAPOR OUTLET FITTING'S ASS'Y R1 2400		
DATE	DR. BY	PRINTED
9-15-84	GL	
SCALE	CHK	
×		
		DWG. & PART NO.
		JP7231

TOLERANCE LIMITS UNLESS OTHERWISE NOTED
 ALL DIMENSIONS IN INCHES
 DECIMAL .005
 FRACTIONAL CASTING 1/16
 SHEET METAL .015
 OTHER .010
 ANGULAR .5
 FILLETS 1/16 MAX RADIUS 1/16 MAX
 ALL MACHINED SURFACES .005 MAX

VAPOR OUTLET FITTINGS ASSEMBLY JP7231

ITEM	QTY	DESCRIPTION	JENNY P/N	VENDOR	VENDOR P/N
1-17	1	Vapor Outlet Fittings Assy	JP7231	JENNY	
2	1	Nipple,PI,S,BLK,SD,1/2x2	JD 721	COML	
4	1	Elbow,ST,90,150,MI,BK, 1/2	JD 800	COML	
5	2	Coupling,SD,S,BK,STT, 1/2	JD1019	COML	
6	3	Bushing, 1/2 x 3/8 BR	JD3053	COML	
7	1	Nipple,PI,S,Blk,SD,1/2x27-1/2	JD3111	COML	
8	1	Stuffing Box	JD3702	COML	
9	1	Elbow, Reducing, ST, 1/2 x 3/8	JD3712	COML	
10	2	Tee, 150, MI,BK, 1/2	JD 696	COML	
11	1	Elbow,90,BR,1/4-45x3/8 NPTM	JD 678	COML	
12	2	Cross,150,MI,BK,1/2	JE 784	COML	
13	4	Nipple,PI,S,BLK,SD, 1/2 CL	JP 981	COML	
14	1	Body, Globe, 3/8 BR, Fig 1	JP2688-01	JENNY	
15	1	Fuse Plug Assembly	JP3921-D	JENNY	
16	1	Nipple,PI,S,BLK,SD,1/2x4	JD 726	JENNY	
17	1	Outlet Bracket RI2400	JP7241	JENNY	
a	Ref.	Drain Relief Valve	JP3284-E	JENNY	

ITEM	PART NO.	QTY.	DESCRIPTION
1	JD 2759	2	CLAMP, PLASTIC, 1/2 x 1/2
2	JD 2917	1	ELBOW, 1/4 NPT x 3/8 TUBE
3	JD 3068	2	CLAMP, 5/8
4	JD 3087	1	PVC TUBING, 3/8 x 8 3/8"
5	JD 1032	2	BUSHING, 3/4 x 1/4
6	JP 7238	1	SOLUTION TANK ASSY.
7	JD 3280	1	TEE, STREET, 1/4
8	JD 2765	1	CONNECTOR, 3/8 TUB. x 1/4 NPT.
9	JD 659	1	CONNECTOR, 1/4-45 x 1/4 NPT.
10	JD 1339	1	TRI-SURE PLUG

G JD 1722-25 - COP. TUBE ASSY.

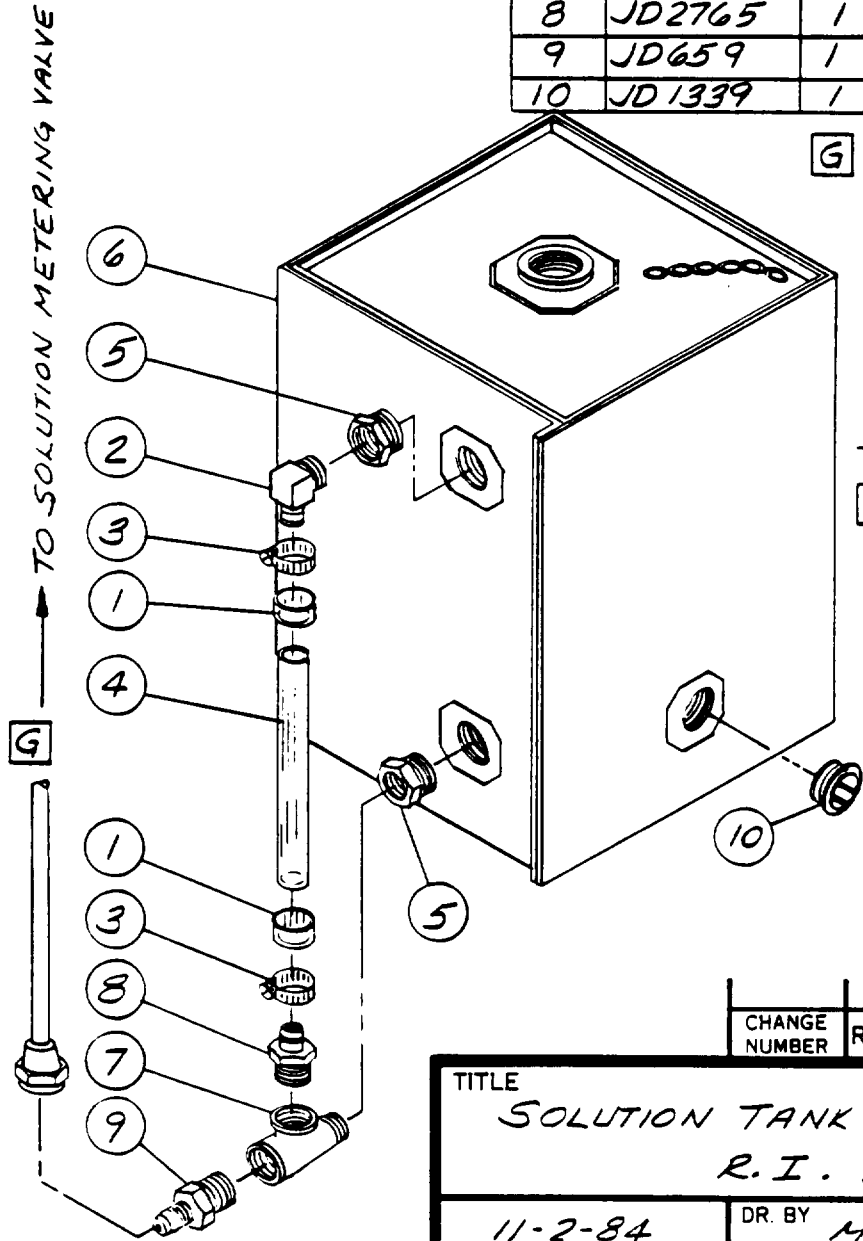

NOTE: FUEL TANK FTGS. ASSY. PER DWG. JP 7110.
 THESE PARTS ARE FOR REF. ONLY AND ARE NOT INCLUDED WITH THIS B/M.

CHANGE NUMBER	REV.	DESCRIPTION	DATE

TITLE (5457)
 SOLUTION TANK & FTGS. ASSEMBLY
 R. I. 2400

11-2-84 DR. BY MJK PRINTED
 SCALE _____ SUPERSEDES

_____ DWG. & PART NO.

 JP 7238-A

TOLERANCES UNLESS OTHERWISE NOTED
 DECIMAL ± .005
 FRACTIONAL CASTINGS ± 1/16 OTHER ± 1/64
 SHEET METAL ± 1/32
 ANGULAR ± 1/4°
 FILLETS: 1/4" MAX. ROUNDS: 1/8" MAX.
 ALL MACHINED SURFACES 125/ MAX.
 ALL DIMENSIONS IN INCHES

BRUNING 40-21 44339

SOLUTION TANK & FTGS. ASSEMBLY JP7238-A

ITEM	QTY	DESCRIPTION	JENNY P/N	VENDOR	VENDOR P/N
1-10	1	Solution Tank & Ftgs. Assy.	JP7238-A	JENNY	
1	2	Clamp, Plastic, 1/2 x 1/2	JD2759	COML	
2	1	Elbow,90,MB,BR,3/8TBx1/4NPTM	JD2917	COML	
3	2	Clamp, Hose,SS,7/32-5/8	JD3068	COML	
4	1	Tubing,PVC,3/8 ODx1/4 ID	JD3087	COML	
5	2	Bushing, 1/4 x 3/4	JD1032	COML	
6	1	Solution Tank Assembly	JP7238	JENNY	
7	1	Tee, 1/4 Street	JD3280	COML	
8	1	Connector,ST,MB,BR,3/8x1/4	JD2765	COML	
9	1	Connector,ST,BR,1/4x1/4NPTM	JD 659	COML	
10	1	Plug,Stl,PIT,w/Poly Gasket (TRI SURE)	JD1339	AMER FLG	212000206
G	1	Copper Tubing Assembly	JD1722-25	COML	

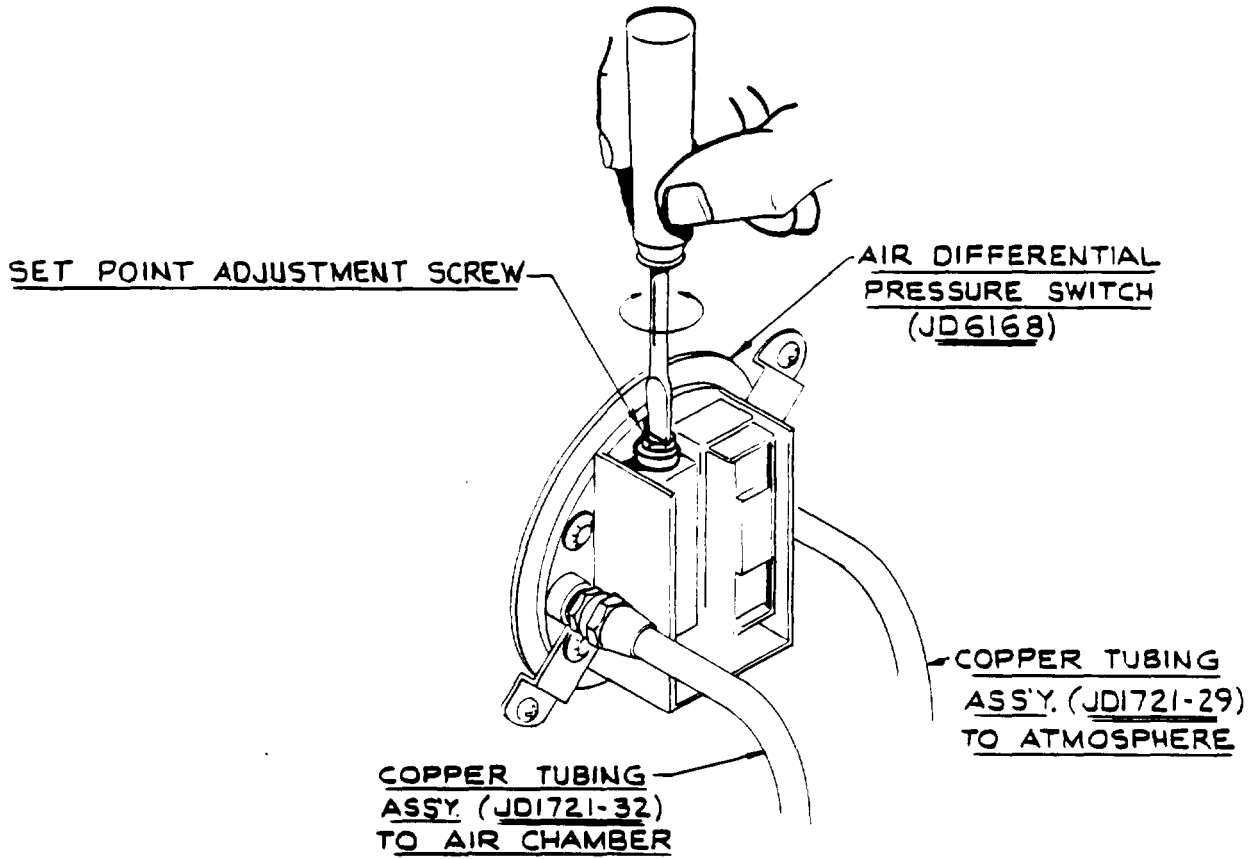

SEE DWG. JP7223-ELEVATIONS
FOR LOCATION

CHANGE NUMBER	REV.	DESCRIPTION	DATE
TITLE			
AIR DIFFERENTIAL SWITCH			
R.I. 2400			
11-9-74	DR. BY SL	PRINTED	
SCALE ~		SUPERSEDES	
DWG. & PART NO.			
			SK-40-84

TOLERANCES UNLESS OTHERWISE NOTED
 DECIMAL ± .005
 FRACTIONAL CASTINGS ± 1/16 OTHER ± 1/64
 SHEET METAL ± 1/32
 ANGULAR ± 4°
 FILLETS: 1/4" MAX. ROUNDS: 1/8" MAX.
 ALL MACHINED SURFACES 125/ MAX.
 ALL DIMENSIONS IN INCHES

BRUNING 40:21 44339

THIS PAGE LEFT INTENTIONALLY BLANK

ADJUSTMENT SCREW

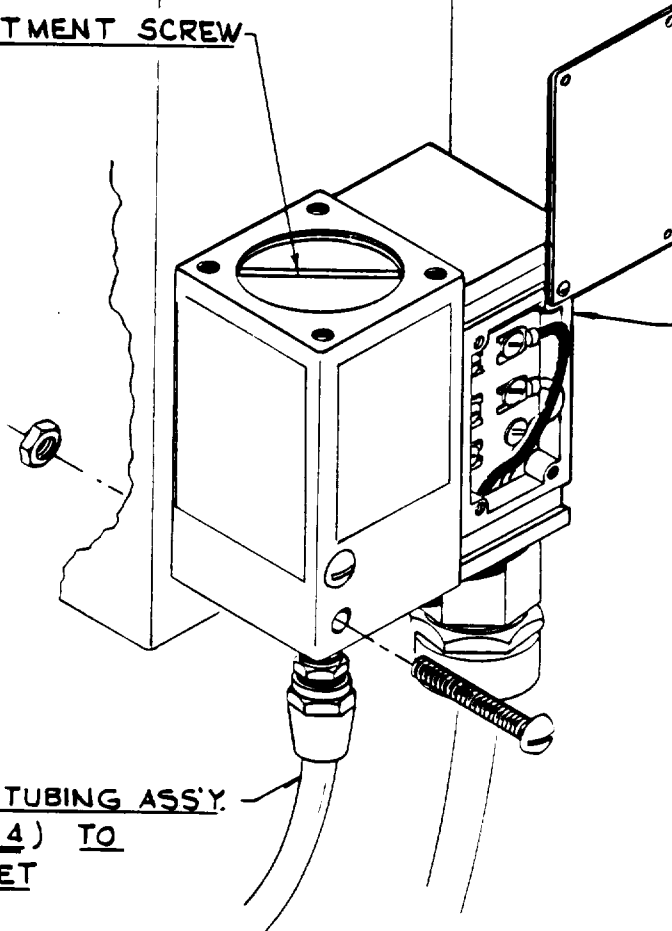

INLET PRESSURE SWITCH
(JD3415)

COPPER TUBING ASS'Y.
(JDI722-14) TO
COIL INLET

SEE ELEVATION DWG. JP7223
FOR LOCATION

CHANGE NUMBER	REV.	DESCRIPTION	DATE

TITLE		
COIL INLET PRESSURE SWITCH		
R.I 2400		
11-12-84	DR. BY SL	PRINTED
SCALE X		SUPERSEDES

TOLERANCES UNLESS OTHERWISE NOTED

DECIMAL ± .005
 FRACTIONAL CASTINGS ± 1/16 OTHER ± 1/64
 SHEET METAL ± 1/32
 ANGULAR ± 1/2°
 FILLETS: 1/4" MAX. ROUNDS: 1/8" MAX.
 ALL MACHINED SURFACES 125 ✓ MAX.
 ALL DIMENSIONS IN INCHES

DWG. & PART NO.	
SK-41-84	

BRUNING 40-21 44339

THIS PAGE LEFT INTENTIONALLY BLANK

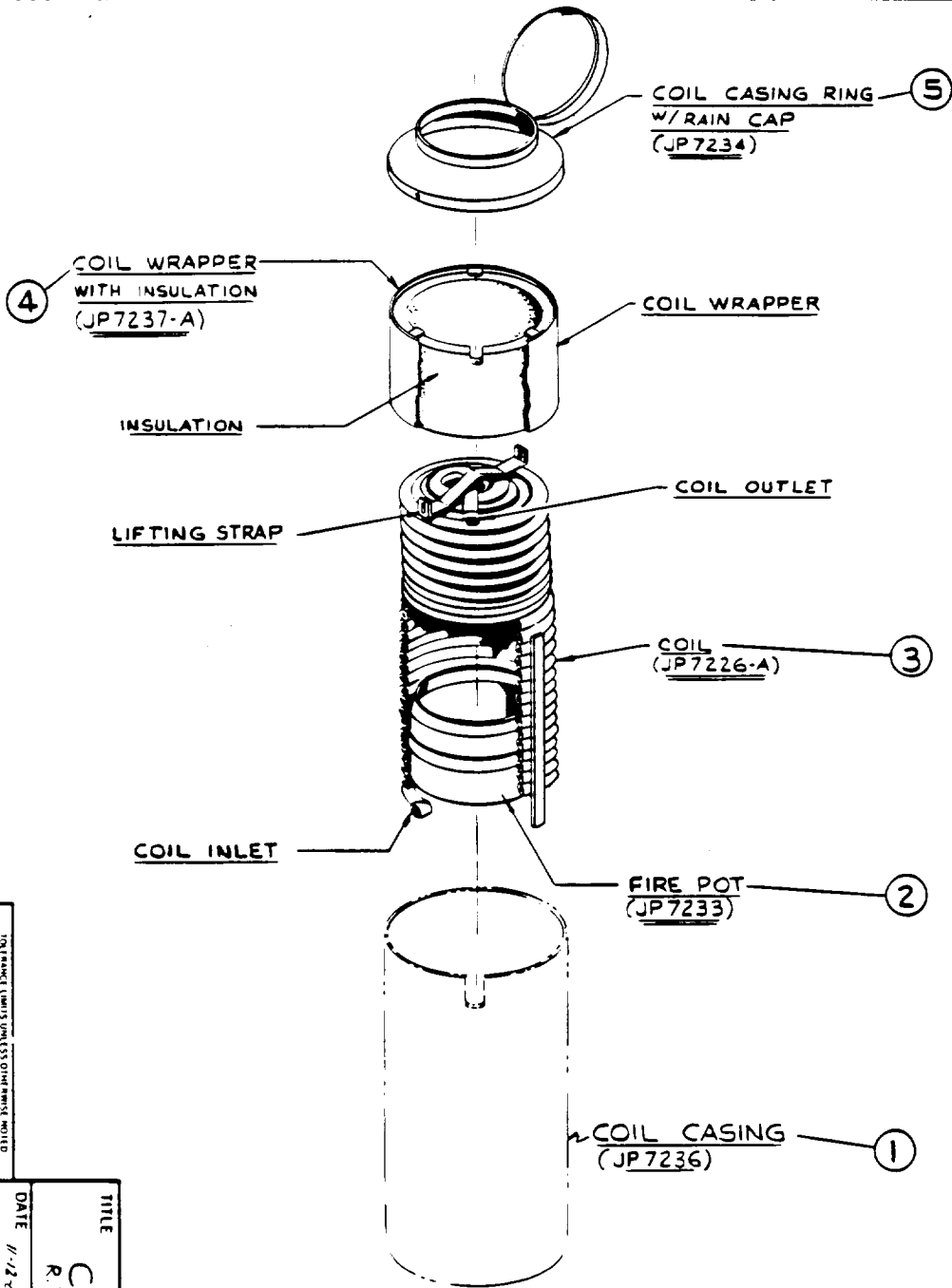

1. DIMENSIONS SHOWN UNLESS OTHERWISE NOTED
 2. ALL DIMENSIONS IN INCHES
 3. DIMENSIONS IN PARENTHESIS ARE FOR REFERENCE ONLY
 4. DIMENSIONS IN PARENTHESIS ARE FOR REFERENCE ONLY
 5. DIMENSIONS IN PARENTHESIS ARE FOR REFERENCE ONLY
 6. DIMENSIONS IN PARENTHESIS ARE FOR REFERENCE ONLY
 7. DIMENSIONS IN PARENTHESIS ARE FOR REFERENCE ONLY
 8. DIMENSIONS IN PARENTHESIS ARE FOR REFERENCE ONLY
 9. DIMENSIONS IN PARENTHESIS ARE FOR REFERENCE ONLY
 10. DIMENSIONS IN PARENTHESIS ARE FOR REFERENCE ONLY

TITLE		COIL ASSY	
R.1 2400			
DATE	11-24-44	DR. BY	fc
SCALE	x	CHK	
PRINTED		DWG. & PART NO.	
SK-42-84			

CHG. NO.	REV.	DESCRIPTION	DATE

COIL ASSEMBLY - SK 42-84

ITEM	QTY	DESCRIPTION	JENNY P/N	VENDOR	VENDOR P/N
1-5	1	Coil Assembly	SK 42-84	JENNY	
1	1	Coil Casing	JP7236	JENNY	
2	1	Fire Pot	JP7233	JENNY	
3	1	Coil	JP7226-A	JENNY	
4	1	Insulated Coil Wrapper	JP7237-A	JENNY	
5	1	Coil Casing Ring with Cap	JP7234	JENNY	

ITEM	PART NO	DESCRIPTION
1	JL 801-A	HOSE, WATER SUPPLY, 50 ft. x 3/4 I.D.
2	JL 801-C	HOSE, WATER SUCTION, 35 ft. x 1 I.D. w/STRAINER FOOT
3	JD 900-J	HOSE, VAPOR 25 ft. x 1/2 I.D.
4	JD 900-K	HOSE, VAPOR 50 ft. x 1/2 I.D.
5	JD 6159	POWER CORD, 14/3 x 75 ft.
6	JD 7008	COTTER, HAIR PIN
7	JP 7227	HOSE RACK ASSEMBLY

* FOR HOSE ASSEMBLIES SEE DWG. SK-8-85

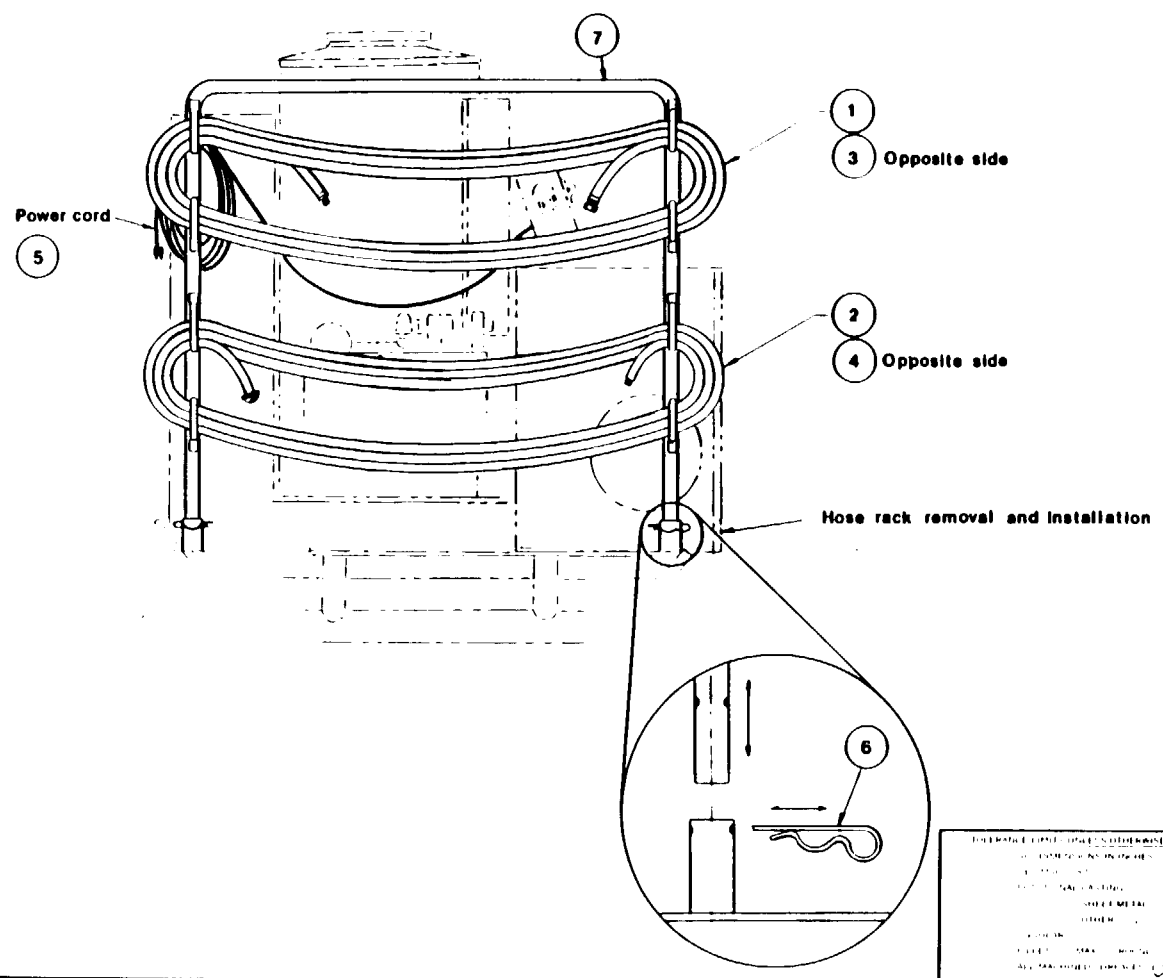

82

5457	Δ	ADDED POWER CORD COTTER PIN	
CHG NO	REV	DESCRIPTION	DATE

TITLE			
HOSE STORAGE			
DATE	DR BY	PRINTED	
11 28 84	SL		
SCALE	CHK	DWG & PART NO	
		SK-45-84	

FOR MATERIALS LIST SEE DRAWING NOTE
 ALL DIMENSIONS IN INCHES
 UNLESS OTHERWISE SPECIFIED
 FINISH: GALV. STEEL
 UNLESS OTHERWISE SPECIFIED
 ALL DIMENSIONS TO CENTER UNLESS OTHERWISE SPECIFIED

HOSE STORAGE SK-45-84

<u>ITEM</u>	<u>QTY</u>	<u>DESCRIPTION</u>	<u>JENNY P/N</u>	<u>VENDOR</u>	<u>VENDOR P/N</u>
1	50'	Hose, Water Supply 3/4 ID	JL 601-A	JENNY	NSN4720-00-585-2289
2	35'	Hose, Water Suction w/strn ft	JL 601-C	JENNY)	
3	25'	Hose, Vapor, 1/2 ID	JD 900-J	JENNY)	Note #1
4	50'	Hose, Vapor, 1/2 ID	JD 900-K	JENNY)	
5	75'	Power Cable	JD6159	JENNY	
6	4	Cotter Hair Pin	JD7008	MCMASTER CARR	98335A094
7	1	Hose Rack Assembly	JP7227	JENNY	

Note #1 - Hose Breakdown shown on SK8-85

PUMP **FUEL** **MAIN POWER** **PRESSURE MODE** **STEAM** **BLOW-DOWN**

TO START UNIT - STEAM MODE

1. Install steam nozzle in cleaning gun.
2. Turn on water supply connected to unit.
3. Turn MODE switch to STEAM position.
4. Open rain cap on coil.
5. Open combustion air baffle to maximum position.
6. Turn main power switch ON, turn pump switch ON.
7. Squeeze gun handle and hold open till water flows from cleaning gun.
8. Turn fuel switch ON.
9. Adjust SOLUTION valve to percentage required. Start with valve OFF (fully clockwise). Open SOLUTION valve (turn control counter clockwise) no more than 1 1/4 turn.

TO START UNIT - PRESSURE MODE

1. Install pressure wash tip in cleaning gun.
2. Turn on water supply connected to unit.
3. Turn MODE switch to PRESSURE position.
4. Open rain cap on coil.
5. Close combustion air baffle to minimum position.
6. Turn MAIN POWER switch ON, turn PUMP switch ON.
7. Squeeze gun handle and hold open till water flows from cleaning gun.
8. Turn fuel switch ON.
9. Adjust SOLUTION valve to percentage required.

TO STOP UNIT

1. Turn SOLUTION valve OFF.
2. Turn fuel switch OFF.
3. Hold gun in the open position until outlet temperature is less than 100°F.
4. Turn PUMP switch OFF, turn main power switch OFF.
5. Close rain cap.

Outlet temperature is a function of incoming water temperature and fuel pressure. Fuel pressure can be field adjusted following instructions in operators manual.
Frequency of maintenance to be as specified in the operators manual.

JP 7203-02

BRUNING 40-21-14339

CHANGE NUMBER	REV.	DESCRIPTION	DATE
---------------	------	-------------	------

TITLE			
SWITCH PANEL R.I. 2400			
2-6-85	DR. BY	PRINTED	
SCALE		SUPERSEDES	
		DWG. & PART NO.	
		SK-7-85	

TOLERANCES UNLESS OTHERWISE NOTED

DECIMAL ± .005
 FRACTIONAL CASTINGS ± 1/16 OTHER ± 1/64
 SHEET METAL ± 1/32
 ANGULAR ± 1/2°
 FILLETS: 1/4" MAX., ROUNDS: 1/8" MAX.
 ALL MACHINED SURFACES 125/ MAX.
 ALL DIMENSIONS IN INCHES

THIS PAGE LEFT INTENTIONALLY BLANK

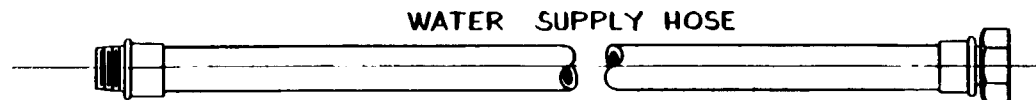

WATER SUPPLY HOSE

① JL 601-A 50^{FT.}

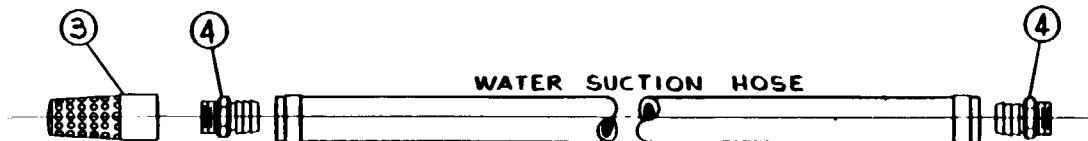

WATER SUCTION HOSE

② JL 601-C 35^{FT.}

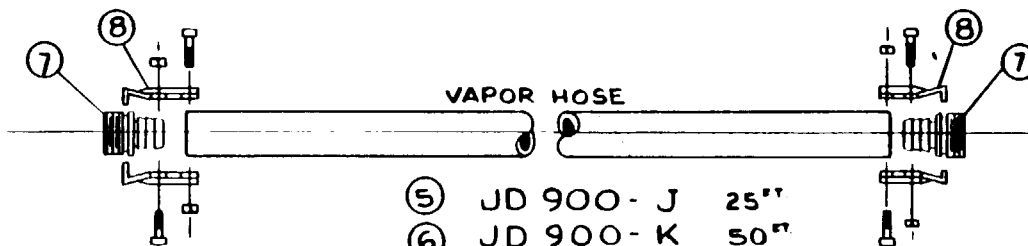

VAPOR HOSE

⑤ JD 900-J 25^{FT.}
⑥ JD 900-K 50^{FT.}

ITEM	QTY	PART NO	DESCRIPTION
1	1	JL 601-A	HOSE, WATER SUPPLY, 50 ^{FT.} , 1/2 I.D.
2	1	JL 601-C	HOSE, SUCTION, 35 ^{FT.} COMPLETE
3	1	JL 168-A	FOOT VALVE w/STRAINER
4	2	JD 765	HOSE SPUD
5	1	JD 900-J	HOSE, VAPOR, 25 ^{FT.} COMPLETE
6	1	JD 900-K	HOSE, VAPOR, 50 ^{FT.} COMPLETE
7	4	JP 882	HOSE SPUD
8	4	JD 140B	CLAMP

86

CHG NO.	REV	DESCRIPTION	DATE

TITLE			
HOSE ASSEMBLIES BREAKDOWN			
P.1. 2400			
DATE	DR. BY	PRINTED	
2-8-85	GC		
SCALE	CHK.		
		DWG & PART NO.	
		SK-8-85	

DIMENSIONS UNLESS OTHERWISE NOTED
 ALL DIMENSIONS IN INCHES
 DECIMALS
 FRACTIONAL CASTING
 SHEET METAL
 OTHER
 ANGULAR
 FILETS 1/4 MAX RADIUS 1/4 MAX
 ALL MACHINED SURFACES 1/25 MAX

HOSE ASSEMBLY BREAKDOWN SK-8-85

ITEM	QTY	DESCRIPTION	JENNY P/N	VENDOR	VENDOR P/N
1	50'	3/4 I.D. Water Supply Hose Complete with Fittings	JL 601-A	NSN	4720-00-585-2289
2	35'	1" Suction Hose Complete	JL 601-C	CONFORMS TO ZZ-H-561 Grade B, Type 1	
3	1	Foot Valve w/Strainer	JL 168A	GRANGER	2X610
4	2	Hose Spud	JD 765	JENNY	
5	25'	Vapor Hose Complete 1/2" I.D.	JD 900-J	JENNY	
6	50'	Vapor Hose Complete 1/2" I.D.	JD 900-K	JENNY	
7	4	HOSE SPUD	JP 882	JENNY	
8	4	CLAMPS	JD 1408	BOSS	Notes 1 and 2

Note 1 - Vendor P/N 9688

Note 2 - NSN 4730-00-496-5957

ITEM	PART NO	QTY.	DESCRIPTION
1	JD2990	1	BLOWER HOUSING
2	JP7209-C	1	AIR BAFFLE ASSY
3	JP7209-03	2	BLOWER BRACKET
4	JD1433	2	THUMB SCREW, 1/4
5	JD787	2	WASHER, FLAT, 1/4
6	JD6050	4	SCREW, #8 x 1/2 LG.

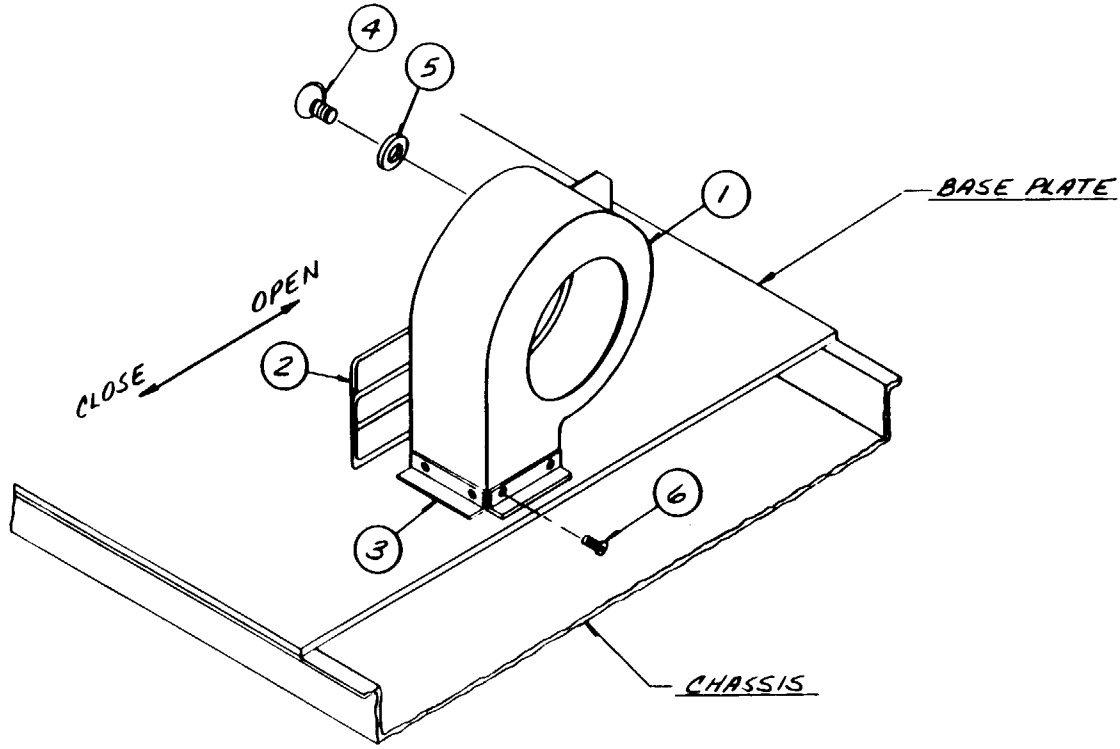

88

CHG NO	REV.	DESCRIPTION	DATE

TITLE			
BLOWER HOUSING ASSEMBLY			
DATE	DR BY	PRINTED	
2-8-85	MLK		
SCALE	CHK.		
		DWG & PART NO.	
		SK-9-85	

ALL DIMENSIONS UNLESS OTHERWISE NOTED
 ALL DIMENSIONS IN INCHES
 FINISHES: 1.000
 2.000
 3.000
 4.000
 5.000
 6.000
 7.000
 8.000
 9.000
 10.000
 11.000
 12.000
 13.000
 14.000
 15.000
 16.000
 17.000
 18.000
 19.000
 20.000
 21.000
 22.000
 23.000
 24.000
 25.000
 26.000
 27.000
 28.000
 29.000
 30.000
 31.000
 32.000
 33.000
 34.000
 35.000
 36.000
 37.000
 38.000
 39.000
 40.000
 41.000
 42.000
 43.000
 44.000
 45.000
 46.000
 47.000
 48.000
 49.000
 50.000
 51.000
 52.000
 53.000
 54.000
 55.000
 56.000
 57.000
 58.000
 59.000
 60.000
 61.000
 62.000
 63.000
 64.000
 65.000
 66.000
 67.000
 68.000
 69.000
 70.000
 71.000
 72.000
 73.000
 74.000
 75.000
 76.000
 77.000
 78.000
 79.000
 80.000
 81.000
 82.000
 83.000
 84.000
 85.000
 86.000
 87.000
 88.000
 89.000
 90.000
 91.000
 92.000
 93.000
 94.000
 95.000
 96.000
 97.000
 98.000
 99.000
 100.000

BLOWER HOUSING ASSEMBLY - SK-9-85

<u>ITEM</u>	<u>QTY</u>	<u>DESCRIPTION</u>	<u>JENNY P/N</u>	<u>VENDOR</u>	<u>VENDOR P/N</u>
1-6	1	Blower Housing Assembly	SK-9-85	JENNY	
1	1	Blower Housing	JD2990	JENNY	
2	1	Air Baffle Assembly	JP7209-C	JENNY	
3	2	Blower Bracket	JP7209-03	JENNY	
4	2	Thumb Screw, 1/4 x 1/2 Lg.	JD1433	COML	
5	2	Washer, Flat, 1/4	JD 787	COML	
6	4	Screw, #8, x 1/2 Lg.	JD6050	COML	

THIS PAGE LEFT INTENTIONALLY BLANK

By Order of the Secretary of the Army:

JOHN A. WICKHAM, JR.
General, United States Army
Chief of Staff

Official:

R. L. DILWORTH
Brigadier General, United States Army
The Adjutant General

DISTRIBUTION:

To be distributed in accordance with DA Form 12-21A, requirements for
Tool Set, Field Ordnance

U.S. GOVERNMENT PRINTING OFFICE : 1994 - 154-713



THEN... JOT DOWN THE DOPE ABOUT IT ON THIS FORM. CAREFULLY TEAR IT OUT. FOLD IT AND DROP IT IN THE MAIL!

SOMETHING WRONG WITH THIS PUBLICATION?

FROM: (PRINT YOUR UNIT'S COMPLETE ADDRESS)

Your Address

DATE SENT

PUBLICATION NUMBER

TM 9-4940-556-14&P

PUBLICATION DATE

PUBLICATION TITLE Cleaner, Steam Pressure Jet Skid Mounted, Model RI 2400

BE EXACT. PIN-POINT WHERE IT IS

PAGE NO	PARA-GRAPH	FIGURE NO	TABLE NC
5	2.25		

IN THIS SPACE TELL WHAT IS WRONG AND WHAT SHOULD BE DONE ABOUT IT:

The word adjustment is misspelled. Please correct it to read adjustment.

SAMPLE

PRINTED NAME, GRADE OR TITLE, AND TELEPHONE NUMBER

MARY SMITH

SIGN HERE

Your Signature

SOMETHING WRONG WITH THIS PUBLICATION?



THEN JOT DOWN THE DOPE ABOUT IT ON THIS FORM. CAREFULLY TEAR IT OUT, FOLD IT AND DROP IT IN THE MAIL.

FROM (PRINT YOUR UNIT'S COMPLETE ADDRESS)

DATE SENT

PUBLICATION NUMBER

TM 9-4940-556-14&P

PUBLICATION DATE

11 JUN 1986

PUBLICATION TITLE Cleaner, Steam Pressure Jet Skid Mounted, Model RI 2400

BE EXACT PIN-POINT WHERE IT IS

Table with columns: PAGE NO, PARA-GRAPH, FIGURE NO, TABLE NO.

IN THIS SPACE TELL WHAT IS WRONG AND WHAT SHOULD BE DONE ABOUT IT:

PRINTED NAME GRADE OR TITLE AND TELEPHONE NUMBER

SIGN HERE

DA FORM 2028-2 1 JUL 79

PREVIOUS EDITIONS ARE OBSOLETE.

AMSMC OP-103-85

PS -IF YOUR OUTFIT WANTS TO KNOW ABOUT YOUR RECOMMENDATION MAKE A CARBON COPY OF THIS AND GIVE IT TO YOUR HEADQUARTERS

TEAR LONG PERFORATION

FILL IN YOUR
UNIT'S ADDRESS



FOLD BACK

DEPARTMENT OF THE ARMY

OFFICIAL BUSINESS

COMMANDER
US ARMY ARMAMENT, MUNITIONS
AND CHEMICAL COMMAND
ATTN: AMSMC-MAS
ROCK ISLAND, IL 61201-9990

TEAR ALONG PERFORATED LINE

RECOMMENDED CHANGES TO EQUIPMENT TECHNICAL PUBLICATIONS



SOMETHING WRONG WITH THIS PUBLICATION?

THEN JOI DOWN THE
DOPE ABOUT IT ON THIS
FORM. CAREFULLY TEAR IT
OUT. FOLD IT AND DROP IT
IN THE MAIL

FROM (PRINT YOUR UNIT'S COMPLETE ADDRESS)

DATE SENT

PUBLICATION NUMBER

TM 9-4940-556-14&P

PUBLICATION DATE

11 JUN 1986

PUBLICATION TITLE Cleaner, Steam
Pressure Jet Skid Mounted, Model
RI 2400

BE EXACT PIN POINT WHERE IT IS

IN THIS SPACE TELL WHAT IS WRONG
AND WHAT SHOULD BE DONE ABOUT IT:

PAGE NO	PARA-GRAPH	FIGURE NO	TABLE NO

TEAR ALONG PERFORATED LINE

PRINTED NAME GRADE OR TITLE AND TELEPHONE NUMBER

SIGN HERE

DA FORM 2028-2
1 JUL 79

PREVIOUS EDITIONS
ARE OBSOLETE

AMSMC OP-103-85

PS --IF YOUR OUTFIT WANTS TO KNOW ABOUT YOUR
RECOMMENDATION MAKE A CARBON COPY OF THIS
AND GIVE IT TO YOUR HEADQUARTERS

FILL IN YOUR
UNIT'S ADDRESS



FOLD BACK

DEPARTMENT OF THE ARMY

OFFICIAL BUSINESS

**COMMANDER
US ARMY ARMAMENT, MUNITIONS
AND CHEMICAL COMMAND
ATTN: AMSMC-MAS
ROCK ISLAND, IL 61201-9990**

TEAR ALONG PERFORATED LINE

RECOMMENDED CHANGES TO EQUIPMENT TECHNICAL PUBLICATIONS



THEN JOY DOWN THE DOPE ABOUT IT ON THIS FORM. CAREFULLY TEAR IT OUT, FOLD IT AND DROP IT IN THE MAIL.

SOMETHING WRONG WITH THIS PUBLICATION?

FROM (PRINT YOUR UNIT'S COMPLETE ADDRESS)

DATE SENT

PUBLICATION NUMBER
TM 9-4940-556-14&P

PUBLICATION DATE
11 JUN 1986

PUBLICATION TITLE Cleaner, Steam
Pressure Jet Skid Mounted, Model
RI 2400

BE EXACT PIN-POINT WHERE IT IS

PAGE NO	PARA GRAPH	FIGURE NO	TABLE NO

IN THIS SPACE TELL WHAT IS WRONG AND WHAT SHOULD BE DONE ABOUT IT:

PRINTED NAME GRADE OR TITLE AND TELEPHONE NUMBER

SIGN HERE

TEAR ALONG PERFORATED LINE

FILL IN YOUR
UNIT'S ADDRESS



FOLD BACK

DEPARTMENT OF THE ARMY

OFFICIAL BUSINESS

**COMMANDER
US ARMY ARMAMENT, MUNITIONS
AND CHEMICAL COMMAND
ATTN: AMSMC-MAS
ROCK ISLAND, IL 61201-9990**

TEAR ALONG PERFORATED LINE

THE METRIC SYSTEM AND EQUIVALENTS

LINEAR MEASURE

1 Centimeter = 10 Millimeters = 0.01 Meters = 0.3937 Inches
 1 Meter = 100 Centimeters = 1000 Millimeters = 39.37 Inches
 1 Kilometer = 1000 Meters = 0.621 Miles

SQUARE MEASURE

1 Sq Centimeter = 100 Sq Millimeters = 0.155 Sq Inches
 1 Sq Meter = 10,000 Sq Centimeters = 10.76 Sq Feet
 1 Sq Kilometer = 1,000,000 Sq Meters = 0.386 Sq Miles

WEIGHTS

1 Gram = 0.001 Kilograms = 1000 Milligrams = 0.035 Ounces
 1 Kilogram = 1000 Grams = 2.2 Lb
 1 Metric Ton = 1000 Kilograms = 1 Megagram = 1.1 Short Tons

CUBIC MEASURE

1 Cu Centimeter = 1000 Cu Millimeters = 0.06 Cu Inches
 1 Cu Meter = 1,000,000 Cu Centimeters = 35.31 Cu Feet

LIQUID MEASURE

1 Milliliter = 0.001 Liters = 0.0338 Fluid Ounces
 1 Liter = 1000 Milliliters = 33.82 Fluid Ounces

TEMPERATURE

$5/9 (^{\circ}\text{F} - 32) = ^{\circ}\text{C}$
 212^o Fahrenheit is equivalent to 100^o Celsius
 90^o Fahrenheit is equivalent to 32.2^o Celsius
 32^o Fahrenheit is equivalent to 0^o Celsius
 $9/5 \text{ C}^{\circ} + 32 = \text{F}^{\circ}$

APPROXIMATE CONVERSION FACTORS

<u>TO CHANGE</u>	<u>TO</u>	<u>MULTIPLY BY</u>
Inches	Centimeters	2.540
Feet	Meters	0.305
Yards	Meters	0.914
Miles	Kilometers	1.609
Square Inches	Square Centimeters	6.451
Square Feet	Square Meters	0.093
Square Yards	Square Meters	0.836
Square Miles	Square Kilometers	2.590
Acres	Square Hectometers	0.405
Cubic Feet	Cubic Meters	0.028
Cubic Yards	Cubic Meters	0.765
Fluid Ounces	Milliliters	29.573
Pints	Liters	0.473
Quarts	Liters	0.946
Gallons	Liters	3.785
Ounces	Grams	28.349
Pounds	Kilograms	0.454
Short Tons	Metric Tons	0.907
Pound-Feet	Newton-Meters	1.356
Pounds per Square Inch	Kilopascals	6.895
Miles per Gallon	Kilometers per Liter	0.425
Miles per Hour	Kilometers per Hour	1.609

<u>TO CHANGE</u>	<u>TO</u>	<u>MULTIPLY BY</u>
Centimeters	Inches	0.394
Meters	Feet	3.280
Meters	Yards	1.094
Kilometers	Miles	0.621
Square Centimeters	Square Inches	0.155
Square Meters	Square Feet	10.764
Square Meters	Square Yards	1.196
Square Kilometers	Square Miles	0.386
Square Hectometers	Acres	2.471
Cubic Meters	Cubic Feet	35.315
Cubic Meters	Cubic Yards	1.308
Milliliters	Fluid Ounces	0.034
Liters	Pints	2.113
Liters	Quarts	1.057
Liters	Gallons	0.264
Grams	Ounces	0.035
Kilograms	Pounds	2.205
Metric Tons	Short Tons	1.102
Newton-Meters	Pound-Feet	0.738
Kilopascals	Pounds per Square Inch	0.145
Kilometers per Liter	Miles per Gallon	2.354
Kilometers per Hour	Miles per Hour	0.621

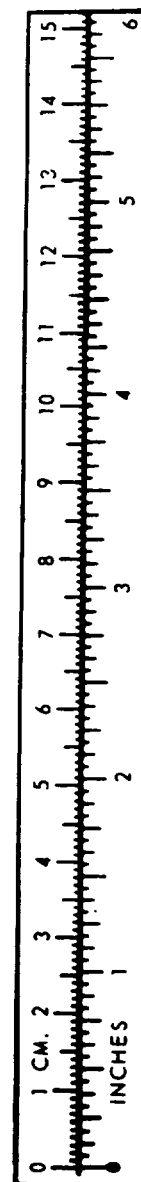

TA089991

PIN: 060001-000